



HAL
open science

A radial-flow device for the biopurification of a model VOC- and wood-smoke- contaminated confined space

Felipe Scott, Christian Vergara-Ojeda, Patricio Moreno-Casas, Cecile Hort, Alberto Vergara-fernández

► To cite this version:

Felipe Scott, Christian Vergara-Ojeda, Patricio Moreno-Casas, Cecile Hort, Alberto Vergara-fernández. A radial-flow device for the biopurification of a model VOC- and wood-smoke- contaminated confined space. *Journal of Chemical Technology and Biotechnology*, 2023, 99 (2), pp.370-380. 10.1002/jctb.7533 . hal-04490630

HAL Id: hal-04490630

<https://univ-pau.hal.science/hal-04490630>

Submitted on 5 Mar 2024

HAL is a multi-disciplinary open access archive for the deposit and dissemination of scientific research documents, whether they are published or not. The documents may come from teaching and research institutions in France or abroad, or from public or private research centers.

L'archive ouverte pluridisciplinaire **HAL**, est destinée au dépôt et à la diffusion de documents scientifiques de niveau recherche, publiés ou non, émanant des établissements d'enseignement et de recherche français ou étrangers, des laboratoires publics ou privés.



Distributed under a Creative Commons Attribution 4.0 International License



ELSEVIER

Contents lists available at ScienceDirect

Biotechnology Advances

journal homepage: www.elsevier.com/locate/biotechadv

Biological treatment of indoor air for VOC removal: Potential and challenges

Benoit Guieysse^{a,*}, Cecile Hort^b, Vincent Platel^b, Raul Munoz^c, Michel Ondarts^b, Sergio Revah^d

^a School of Civil and Environmental Engineering, Nanyang Technological University, Block N1, Nanyang Avenue, Singapore 639798, Singapore

^b Laboratoire de Thermique, Energétique et Procédés, Université de Pau et des Pays de l'Adour, Quartier Bastillac, 65000 Tarbes, France

^c Valladolid University, Department of Chemical Engineering and Environmental Technology, Paseo del Prado de la Magdalena, s/n, Valladolid, Spain

^d Universidad Autónoma Metropolitana-Cuajimalpa c/o UAM-I, Departamento de Ingeniería de Procesos e Hidráulica, Av. San Rafael Atlixco No. 186, Col. Vicentina, C.P. 09340, México, Distrito Federal, Mexico

ARTICLE INFO

Article history:

Received 17 December 2007

Received in revised form 25 March 2008

Accepted 29 March 2008

Available online xxxx

Keywords:

Biofiltration

Indoor air quality

Sick-building syndrome

Volatile organic compound

Green building

ABSTRACT

There is nowadays no single fully satisfactory method for VOC removal from indoor air due to the difficulties linked to the very low concentration ($\mu\text{g m}^{-3}$ range), diversity, and variability at which VOCs are typically found in the indoor environment. Although biological methods have shown a certain potential for this purpose, the specific characteristic of indoor air and the indoor air environment brings numerous challenges. In particular, new methods must be developed to inoculate, express, and maintain a suitable and diverse catabolic ability under conditions of trace substrate concentration which might not sustain microbial growth. In addition, the biological treatment of indoor air must be able to purify large amounts of air in confined environments with minimal nuisances and release of microorganisms. This requires technical innovations, the development of specific testing protocols and a deep understanding of microbial activities and the mechanisms of substrate uptake at trace concentrations.

© 2008 Published by Elsevier Inc.

Contents

1. Introduction	0
2. Indoor air quality	0
3. VOCs and indoor air quality.	0
4. Indoor air treatment	0
5. Biological treatment of indoor air	0
5.1. Influence of type of VOCs	0
5.2. Influence of low concentrations on biomass productivity and transfer rates.	0
5.3. Impact of purification efficiency on design	0
5.4. Humidification and biohazards.	0
5.5. Esthetic, noise, purification perception	0
5.6. Evaluating performance	0
6. Designing biological purifiers	0
7. Conclusions	0
8. Uncited references	0
Acknowledgments.	0
References	0

1. Introduction

Indoor air contamination is a complex problem involving particles (such as dust and smoke), biological agents (molds, spores), radon,

asbestos, and gaseous contaminants such as CO, CO₂, NO_x, SO_x, aldehydes and VOCs (Volatile Organic Compounds) (Table 1). The latter are strongly suspected to cause many Indoor Air Quality (IAQ) associated health problems and “sick-building” symptoms (Wallace, 2001; Jones, 1999; Wieslander et al., 1997; Yu and Crump, 1998).

Singularly, despite the abundance of evidence linking the exposure to VOCs in indoor air with various health effects, only few reports evaluating the existing abatement technologies are currently

* Corresponding author. Tel.: +65 6790 5282; fax: +65 6791 0676.

E-mail address: bjguieysse@ntu.edu.sg (B. Guieysse).

Table 1
Typical air pollutants in indoor air (US EPA)

Group	Definition/example	Origin	Toxic effects
Particles	Very small liquid or solid substances in suspension in the air: mists, dust, pollen, cigarette smoke, viruses, bacteria, molds	Outdoor air, combustion, carpets, human activity, decaying building	Irritation to eyes and/or respiratory tissues, allergies, cancer, indirect effect through biological production of toxins.
Gaseous pollutants	CO, CO ₂ , NO _x , formaldehyde, VOCs	Combustion, human activity, building materials, furniture, cleaning products, mold development etc.	Irritation to eyes and/or respiratory tissues, allergies, cancer, effects on the respiratory liver, immune, reproductive and/or nervous system
Radon and its progeny	Radioactive gases	Rock, soil, groundwater, natural gas, mineral building materials	Lung cancer

available. Several studies have demonstrated the potential of biological methods to remove indoor VOCs (Wolverton et al., 1984; Wolverton et al., 1989; Darlington et al., 2000; Darlington et al., 2001; Chen et al., 2005; Orwell et al., 2006; Wood et al., 2006). However, there is still a lack of solid and relevant data available to understand the true removal mechanisms in these systems and the apparent mismatch between experimental observations and theoretical results from transfer-based models on air biological treatment, as demonstrated in this review. This paper presents a critical review on the potential of biological technologies for indoor air purification with the dual objective of providing a state of the art of the relevant literature and a roadmap for future research. For the latter purpose, a scale-down approach was used in order to understand the consequences of indoor biological treatment on microbial growth and process design. Then, we identified current knowledge gaps hindering the proper understanding and development of biological processes for indoor air VOC removal. In the following, the term "biological purifier" is used to describe any device including a biological component (botanical or microbial) used for VOC removal; "botanical purifier" was used to specifically describe devices using plants and their associated microorganisms. Classical systems were named according to the conventional air treatment nomenclature (Revah and Morgan-Sagastume, 2005).

2. Indoor air quality

Because Americans spend nearly 90% of their time indoors and nearly 25% of US residents are affected by poor IAQ either at the workplace or at home, the US Environmental Protection Agency (EPA) ranks poor IAQ among its largest national environmental threats. Its counterpart, the European Environmental Agency (EEA) has pointed out IAQ as one of the priority concerns in children's health and similar issues are faced worldwide (Zhang and Smith, 2003; Observatory on Indoor Air Quality, 2006; Zumairi et al., 2006). In fact, some buildings contain such high levels of contaminants that they are qualified as "sick" because exposure to them results in multiple sickness symptoms (e.g. headache, fatigue, skin and eye irritations, or respiratory illness) commonly described as the "sick-building syndrome" (SBS) (Burge, 2004).

Data on IAQ-health related effects is still lacking and sometimes contradictory. For instance, Pilotto et al. (1997) found a strong link between exposure to peak NO₂ concentration and respiratory infections in children aged 6–10 years whereas other authors failed to establish this association (Brunekreef et al., 1990; Samet et al., 1993). Nevertheless, it has been suggested that indoor air pollution causes between 65,000 and 150,000 deaths per year in the US, which is comparable to outdoors pollution induced mortality (Lomborj, 2002). IAQ also impacts work productivity as for instance Wargocki et al. (1999) showed subjects exposed to a typical indoor pollution source (plastic carpet) typed 6.5% less than control subjects. Likewise, empirical studies have shown that the use of ventilation rates lower than 25 L s⁻¹ per person in commercial and institutional buildings was correlated to an increase in the number of short-term sick leaves

(Sundell, 2004). It has therefore been estimated that 40–200 billions USD could be annually saved or gained by improving IAQ in the USA only (in 1996 USD; Fisk, 2000). This problem is already driving an important IAQ market that reached \$5.6 billion in 2003 in the USA where it was expected to rise up to \$9.4 billion by 2008 (Market report: indoor air quality, 2004).

3. VOCs and indoor air quality

Interestingly, there is no clear or unanimous definition of what is a VOC: The US EPA defines VOCs as substances with vapor pressure greater than 0.1 mm Hg, the Australian National Pollutant Inventory as any chemical based on carbon chains or rings with a vapor pressure greater than 2 mm Hg at 25 °C, and the EU as chemicals with a vapor pressure greater than 0.074 mm Hg at 20 °C. Chemicals such as CO, CO₂, CH₄, and sometimes aldehydes, are often excluded. In addition, sub-classifications such as Very Volatile Organic Compounds (VVOCs) or Semi Volatile Organic Compounds (SVOCs) have been used in the context of IAQ (Crump, 2001; Ayoko, 2004).

Several organizations such as the World Health Organization (WHO), the US EPA, or the OQAI (French Indoor Air Quality Observatory), have established lists of priority indoor air pollutants (WHO, 2000; Johnston et al., 2002; Mosqueron and Nedellec, 2002, OQAI) based on the ubiquity, concentration and toxic effect of the substances involved. These lists are relatively similar and systematically include aldehydes, aromatics, and halogenates as well as biocides. Differences are due to the type of pollution taken into account (only chemicals for the EPA, no mixtures such as tobacco smoke for the OQAI) and the geographic specificities of indoor air pollution. Indeed, variations in the building materials, cleaning products, or type of ventilation used generate differences in the indoor air pollution (Sakai et al., 2004). These priority lists will most likely evolve upon new analytical and toxicological findings more relevant to IAQ such as the health effects of chronic exposure to multiple pollutants at low concentration (Mosqueron and Nedellec, 2002). This lack of relevant knowledge probably explains why there are only few guidelines for VOC indoor air concentration currently available (WHO, 2000; Canada, 1987).

Hundreds of VOCs can be simultaneously found in indoor air. These compounds exhibit very large variations in concentration as well as physical, chemical, and biological properties. Furthermore, the composition of the mixture greatly varies in time as the concentration of VOCs released from coating and furniture generally decreases in time whereas the release of certain substances depends on punctual human activities or even human breathing (Ekberg, 1994; Phillips, 1997; Miekisch et al., 2004). Primary emissions of VOCs constitute the major source in new or renovated dwellings during the first months, while physical and chemical deterioration of buildings material (named secondary emission) later becomes the main mechanisms of VOC release (Wolkoff and Nielsen, 2001; Yu and Crump, 1998). Indoor VOC concentrations depend on the total space volume, the pollutant production and removal rates, the air exchange rate with the outside atmosphere, and the outdoor VOCs concentrations (Salthammer,

t2.1 **Table 2**
t2.2 Example of VOCs found in indoor air

Compound	CAS ^a	Priority list		Indoor concentration ($\mu\text{g m}^{-3}$)			Recommended values ($\mu\text{g m}^{-3}$)	IARC ^c	Health effects	References
		EPA OQAI ^b	WHO	Min	Max	Average				
Acetaldehyde	75-07-0	×	HP	3.24	119	18.9	LFC ^d	2B	Respiratory disorders, irritation of the eyes	Weisel et al. (2005) Mosqueron and Nedellec (2002)
Benzene	71-43-2	×	HP	×	0.48	364	2.90	1	Immunological disorders, leukemia, neurological effect	Weisel et al. (2005) Edwards et al. (2001)
Dieldrin	60-57-1	×	VP	×	6.00×10^{-4}	7.00×10^{-5}	–	3	Neurological effect, cancer of the liver	Mosqueron and Nedellec (2002)
Dichlorvos	62-73-7	×	HP	×	2.24	0.455	–	2B	Neurological effect, cancer of the liver	Mosqueron and Nedellec (2002)
Formaldehyde	50-00-0	×	HP	×	11.2	53.8	20.1	1000 (1 h)	Respiratory disorders, irritation of the eyes	Weisel et al. (2005) Edwards et al. (2001)
Naphthalene	91-20-3	×	×	×	2.20	90.1	–	2B		Mosqueron and Nedellec (2004)
Tetrachlorethylene	127-18-4	×	VP	×	0.10	20.9	0.56	250	Neurological effect, renal disorder	Weisel et al. (2005)
						73.6	1.38	LFC ^d		Mosqueron and Nedellec (2002)
Toluene	108-88-33	×	VP	×	2.83	122	10.1	260	Neurological effect	Weisel et al. (2005) Edwards et al. (2001)
						247	14.6			
Trichlorethylene	79-01-6	×	VP	×	0.04	7.84	0.12	2.3	Neurological effect, cancer of the testicles	Weisel et al. (2005)
						41.8	0.86	LFC ^d		Mosqueron and Nedellec (2002)

t2.20 ^a Chemical Abstract Service.

t2.21 ^b HP: Highly Priority, VP: Very Priority.

t2.22 ^c International Agency for Research on Cancer (IARC) classification: Group 1: agent carcinogenic to humans, group 2A: agent probably carcinogenic to humans, group 2B: agent possibly carcinogenic to humans, Group 3: agent not classifiable as to humans, group 4: agent not carcinogenic to humans, ns: non-study.

t2.23 ^d NIOSH recommended for the carcinogenic Lowest Feasible Concentration.

t2.24 ^e Canada (1987).

159 1997). Typical air exchange rates in rooms without mechanical
160 ventilation systems range from 0.1 to 0.4 h⁻¹, as stated above. Indoor
161 VOCs concentrations are generally higher than outdoor concentra-
162 tions because VOCs can be released from human activities and a wide
163 variety of materials such as floorings, linoleum, carpets, paints, surface
164 coatings, furniture etc (Yu and Crump, 1998). Salthammer (1997) for
165 instance showed furniture coatings could release 150 VOCs (mainly
166 aliphatic and aromatic aldehydes, aromatic hydrocarbons, ketones,
167 esters and glycols) at Total VOC (TVOC) concentrations up to 1288 $\mu\text{g m}^{-3}$
168 in test chamber studies and TVOCs emission rates as high as
169 22,280 $\mu\text{g m}^{-2} \text{h}^{-1}$ have been recorded from vinyl/pvc flooring (Yu and
170 Crump, 1998). Molds and bacteria can contribute significantly to the
171 presence of particles (spores) or VOCs in indoor pollution (Schlei-
172 binger et al., 2004). Microbial development in buildings can be found
173 in places where humidity accumulates including defective heating
174 and air conditioning systems, garbage disposal, bathrooms, water
175 leaks etc. and has been shown to provoke toxic and allergenic
176 responses. Thus, although the individual concentrations of each
177 contaminant are generally low ($\mu\text{g m}^{-3}$), several hundreds of
178 contaminants can be found simultaneously, resulting in significant TVOC
179 levels. Kostianen (1995) found that individual concentrations of
180 selected pollutants were 5–1000 times higher in 38 Finish sick-houses
181 (defined as houses in which people experienced symptoms associated
182 with SBS) than their mean concentrations in 50 normal houses used as
183 reference, with over 200 VOCs being simultaneously detected in 26
184 houses. The same study also reported a maximal TVOC concentration
185 of 9538 $\mu\text{g m}^{-3}$ in one sick house compared to the mean concentration
186 of 121 $\mu\text{g m}^{-3}$ recorded in the normal houses. Likewise, Brown and
187 Crump (1996) recorded TVOC concentrations up to 11,401 $\mu\text{g m}^{-3}$ in
188 UK homes and Daisey et al. (1994) reported indoor TVOC concentra-
189 tions of 230–700 $\mu\text{g m}^{-3}$ (geometric mean of 510 $\mu\text{g m}^{-3}$) in 12
190 Californian office buildings. It is not easy to correlate TVOC with health
191 effects because this generic parameter does not reflect the individual
192 differences in toxicities found among indoor air VOCs; however,
193 experience of eye, nose or mouth irritation has been reported at
194 5000–25,000 $\mu\text{g TVOC m}^{-3}$ (Andersson et al., 1997).

195 Although indoor VOCs such as benzene or some polycyclic
196 aromatic hydrocarbons are recognized as human carcinogens, a direct
197 association between VOCs exposure and SBS symptoms or cancer has
198 not been fully established at typical indoor air concentrations
199 (Wallace, 2001). Several studies however correlated exposure to low
200 concentrations of these pollutants with increased risks of cancer or
201 eye and airways irritations (Table 2) (Vaughan et al., 1986, Wallace,
202 1991, Wolkoff and Nielsen, 2001). Symptoms such as headache,
203 drowsiness, fatigue and confusion have been recorded in subjects
204 exposed to 22 VOCs at 25 $\mu\text{g m}^{-3}$ (Hudnell et al., 1992). Likewise,
205 exposure to 1000 $\mu\text{g m}^{-3}$ of formaldehyde causes coughing and eye
206 irritation. In addition, many harmless VOCs can react with oxidants
207 such as ozone, producing highly reactive compounds that can be more
208 harmful than their precursors, some of which are sensory irritants
209 (Sundell, 2004; Wolkoff et al., 1997; Wolkoff and Nielsen, 2001).
210 Finally, most of the reported concentrations based on stationary
211 measurement might lead to an underestimation of the real exposure
212 dose of the subjects evaluated in epidemiological studies because
213 concentrations in the breathing zone could be 2 to 4 times higher than
214 those recorded with traditional methods (Rodes et al., 1991; Wallace,
215 1991; Wolkoff and Nielsen, 2001).

4. Indoor air treatment

216
217 Existing solutions to poor indoor air quality include combination of
218 actions such as removing the pollutant sources; increasing ventilation
219 rates and improving air distribution; and cleaning the indoor air (US
220 EPA). Although certain furniture or appliance-manufacturers are
221 already phasing out the use of formaldehyde, removing the pollutant
222 sources is only possible when these are known and control is
223 technically or economically feasible, which is seldom the case. New
224 substances are constantly detected and classified as hazardous and
225 many sources can release compounds for years. In addition, there
226 are fears that many air pollutants are yet to be discovered (Otake
227 et al., 2001; Carlsson et al., 2000; Muir and Howard, 2006) and pre-
228 ventive approaches might therefore be needed to ensure indoor air

Table 3
Current and emerging indoor air treatment methods: principle, examples and limitations

Method	Principle
<i>Current methods</i>	
Filtration	Air is passed through a fibrous material (often coated with a viscous substance), which is efficient for particle removal but not gases. Filters are compact and commonly used but their efficiency decreases as they become saturated (fouling). Microorganisms can also develop in filters and particles reemission might occur.
Electrostatic precipitator with ionization	An electric field is generated to trap charged particles. Electrostatic precipitators are often combined with ion generators that charge particles. Remove efficiently particles, are, compact, commonly used but can generate hazardous charged particles.
Adsorption	Air pollutants are adsorbed onto activated carbon or zeolites, often as filtration post-treatment. The adsorbent might be too specific and might saturate fast because the pollutant are not destructed. There is therefore a potential risk of pollutant reemission.
Ozonation	Ozone is generated to oxidize pollutants. Only remove some fumes and certain gaseous pollutants and might generate unhealthy ozone and degradation products. Ozone-based purifiers are not recommended by the American Lung Association.
Photolysis	High energy ultra violet radiation oxidizes air pollutants and kills pathogens. It can however only remove some fumes and some gaseous pollutants and might release toxic photoproducts. Accidental exposure to UV light is harmful and UV irradiation is energy consuming.
Photocatalysis	High energy ultra violet radiation is used in combination with a photocatalyst (TiO ₂) to generate highly reactive hydroxyl radicals that can oxidize most pollutants and kill pathogens. This energy-intensive method is increasingly popular and suitable for a broad range of organic pollutants.
<i>Emerging methods</i>	
Membrane separation	Pollutants are passed through a membrane into another fluid by affinity separation. This method is normally recommended for highly loaded streams and has yet to be proven at low VOC levels. If the separated VOC are not reused, membrane filtration must be completed with a destruction step.
Enzymatic oxidation	Air pollutants are transferred into an aqueous phase where they are degraded by suitable enzymes Little information is however available concerning the efficiency of the commercial system (Air and Water Solution Inc., USA, http://www.srebiotech.com/) and new enzymes must be supplied periodically.
Botanical purification	Air is passed through a planted soil or directly on the plants. The contaminants are then degraded by microorganisms and/or plants, the precise mechanisms being unclear. Although the efficiency of botanical purification has not been fully proven, a number of devices have been patented and several commercial products are available.
	US patent 6,676,091 for instance discloses a device where air is forced directly through a vertical (or slightly inclined) porous material serving as support for hydroponic plants, the plant's main purpose being to support the activity of pollutant degrading microorganisms in their rizosphere. This device is rather large in regards to other technology but can be use for interior design purposes.
Biofilters and biotrickling filter	Air is passed through a packed bed of a solid support colonized by attached microorganisms that biodegrade the VOCs. In one configuration, air was purified through lava rocks covered with a geotextile cloth supporting mosses (Darlington et al., 2001).

climate control, or noise. Periodical air refreshing is often not efficient because many indoor air pollutants are constantly released. Hence, forced ventilation is still one of the most common methods used for air treatment (Wargocki et al., 2002). The improvement of indoor air quality and energy savings are encouraged in the EU and by movements such as the "Green Building" (US Green Building Council), which means that forced ventilation should be reduced at the same time as IAQ should be improved. In a worst case scenario (no heat recovery from ventilation) the energy requirements for heating a commercial office of 100 m² and 2.5 m of height at 23 °C ventilated with outdoor air (4 °C) at an air exchange rate of 3 room volumes per hour is approx. 3420 kWh/month (or about 340 USD, based on residential electricity prices in 2006). Consequently, there are few alternatives left than purifying the air inside the building.

Current methods for air purification include combinations of air filtration, ionization, activated carbon adsorption, ozonation, and photocatalysis (Table 3). These processes can be integrated into the central ventilation system (in duct) or used in portable air purifiers (or air cleaner) designed for limited spaces. Efficient strategies for particle removal are now well established and include combinations of filtration and electrostatic precipitation. The situation is however very different for VOC removal. For instance, in a study conducted to compare several commercial air purifiers, Shaughnessy et al. (1994) concluded that, although high efficiency particles air filters (HEPA filters) and electrostatic precipitators were highly efficient for particle removal, none of the techniques tested (HEPA filtration, electrostatic precipitation, ionization, ozonation, activated carbon adsorption) could significantly remove formaldehyde. A similar study was recently conducted to compare 15 air cleaners with a mixture of 16 representative VOCs (Chen et al., 2005). The technologies evaluated included sorption filtration, ultraviolet-photocatalytic oxidation (UV-PCO), ozone oxidation, air ionization and a botanical purifier prototype (where contaminated air was blown through the rizosphere of plants and contaminants were in principle removed by soil microorganisms, the plants or their enzymes through various mechanisms). The results were:

1. Among the 7 air cleaners using activated carbon in combination with HEPA filter and/or ionizer, the best single pass removal efficiencies achieved for formaldehyde, toluene and dodecane were 4, 32 and 39%, respectively (these contaminants were selected for being representative of soluble, semi-soluble and unpolar substances).
2. The commercial UV-PCO purifier did not effectively remove any of the tested VOCs, although a "properly designed" device was effective for certain VOCs (no data presented).
3. None of the ozone generator systems significantly removed any of the VOCs tested; some even released ozone to concentrations much higher than the safety limit set by the OSHA (Occupational Safety and Health Administration).
4. The botanical purifier was able to remove around 20% of formaldehyde (single pass) but no toluene and only 4% of dodecane.

From this data, the authors concluded that only the biological system significantly removed very volatile organic compounds, such as formaldehyde, in contrast to the adsorption processes that generally only satisfactorily removed the poorly soluble contaminants. The overall elimination capacity (g VOC removed d⁻¹) of the botanical purifier for formaldehyde was however lower than the best activated carbon based device because the biological purifier could not be operated at high air flows. An air exchange rate of 3 room volumes per hour is generally recommended for indoor air treatment, which means that very large amounts of air must be treated into relatively small units (for suitable use in the indoor space without visual or noise nuisances). This might be difficult to achieve in botanical purifiers where air is ventilated into the soil through the roots.

contaminants are maintained below satisfactory levels at all times. Natural aeration is the easiest alternative but it is often not possible because of outdoor weather, external pollution conditions (Ekberg, 1994; Daisey et al., 1994) or issues of security, safety in high buildings,

t4.1 **Table 4**
t4.2 Biodegradability of typical indoor VOCs

Substance	Biodegradability ^a	Henry's law constants		Biological treatment			
		H^b (atm m ³ mol ⁻¹)	References	Inlet concentration ^c (mg m ⁻³)	Removal efficiency (%)	Biological treatment ^d	References
Acetaldehyde (Ethanal; CH ₃ CHO)	3	5.88 10 ⁻⁵	Zhou and Mopper (1990)	18.1–180.1 ^e	40–80	B	Mohd Adly et al. (2001)
		7.69 10 ⁻⁵	Sander (1999)				
		5.88 10 ⁻⁵	US EPA (1982)				
Benzene (C ₆ H ₆)	2	6.25 10 ⁻³	Staudinger and Roberts (1996)	1.6 ^e	9–77	B	Ergas et al. (1992)
		5.55 10 ⁻³	US EPA (1982)	0.32–1.28 ^e	50 to 60	BF	Wolverton et al. (1989)
		4.76 10 ⁻³	Sander (1999)	0.048–0.48 ^e	20	PW	Darlington (2004)
Formaldehyde (Methanal; HCHO)	3	3.33 10 ⁻⁷	Sander (1999)	0.12–0.49 ^e	50 to 60	BF	Wolverton et al. (1989)
		3.23 10 ⁻⁷	Zhou and Mopper (1990)	0.018–0.18 ^e	90	BF	Darlington (2004)
		3.13 10 ⁻⁷	Staudinger and Roberts (1996)				
Naphthalene (C ₁₀ H ₈)	1	4.76 10 ⁻⁴	Sander (1999)	0.494 ^e	75	TPPB	MacLeod and Daugulis (2003)
		4.76 10 ⁻⁴	US EPA (1982)				
Tetrachlorethylene (Tetrachloroethene; C ₂ Cl ₄)	1	2.78 10 ⁻²	US EPA (1982)	0.678 ^e	12–49	B	Ergas et al. (1992)
		1.69 10 ⁻²	Staudinger and Roberts (1996)	0.36–4.80 ^e	0–8	BTr	Torres et al. (1996)
		1.56 10 ⁻²	Sander (1999)				
Toluene (Methylbenzene; C ₆ H ₅ CH ₃)	2	6.67 10 ⁻³	US EPA (1982)	1.88 ^e	14–78	B	Ergas et al. (1992)
		6.67 10 ⁻³	Staudinger and Roberts (1996)	753.5	50	MS	Ergas (1999)
				0.226–0.301 ^e		BF	Darlington (2001)
				0.057–0.57 ^e		BF	Darlington (2004)
Trichlorethylene (Trichloroethene; C ₂ HCl ₃)	1	9.09 10 ⁻³	Sander (1999)	107.44	30	MS	Parvatiyar et al. (1996)
		1.12 10 ⁻²	US EPA (1982)	0.081–0.81 ^e	0	BF	Darlington (2004)
		1.00 10 ⁻²	Staudinger and Roberts (1996)	0.054–2.149 ^e	50 to 60	BF	Wolverton et al. (1989)
				0.01–0.04 ^e	0–24	BTr	Torres et al. (1996)

t4.27 ^a 1 = low biodegradability, 2 = moderate biodegradability, 3 = good biodegradability (Shareefdeen and Singh, 2005; Deviny et al., 1999).

t4.28 ^b Under standard conditions.

t4.29 ^c Concentrations close to the average concentration observed in indoor air.

t4.30 ^d B = Biofiltration; MS = Membrane Separation; BF = Botanical Filter; TPPB = Two-Phase Partitioning Bioreactor; BTr = Biotrickling Filter.

t4.31 ^e In mixture with other compounds.

298 Membrane mediated VOCs removal in indoors air has been also
299 recently evaluated. Formaldehyde and benzene were significantly
300 removed at concentrations of 11,500 and 6500 µg m⁻³, respectively
301 using a zeolite membrane operated at permeation fluxes of 0.01 and
302 0.0056 g m⁻² h⁻¹, respectively (Aguado et al., 2004). Further studies must
303 however demonstrate pollutant removal at concentrations relevant to
304 indoors environments (approx. one order of magnitude lower than those
305 tested) and provide solutions to destroy the VOCs following separation.

306 5. Biological treatment of indoor air

307 There is little data available on the biological removal of VOCs from
308 indoor air and all the studies hitherto conducted have, to the best of
309 our knowledge, focused on botanical purifiers. In a pioneer study
310 supported by the NASA, Wolverton and co-authors demonstrated the
311 potential of plants (and their rizosphere) to remove indoor VOCs in
312 sealed chamber. In their earliest study (Wolverton et al., 1984), the
313 authors found that several plants could remove formaldehyde at
314 19,000–46,000 µg m⁻³ to levels lower than 2500 µg m⁻³ (detection
315 limit) in 24 h. Similar studies were conducted with benzene and
316 trichloroethylene at more relevant concentrations of 325–2190 µg m⁻³
317 (Wolverton et al., 1989). It was then found that the 8 plants tested
318 could remove benzene by 47–90% in 24 h compared to 5–10% in the
319 control tests, and that the rizosphere zone was the most effective area
320 for removal. Orwell et al. (2004) later investigated the potential of
321 indoor plants for removing benzene in sealed chamber (0.216 m³) and

found that microorganisms of the plant rizosphere were mainly
responsible for benzene removal (40–80 mg m⁻³ d⁻¹). These results
were obtained at high initial benzene concentrations (81,000–
163,000 µg m⁻³) and benzene removal rate increased linearly with
the dose concentration, suggesting the system might be inefficient
under typical indoor air conditions. However, the same team more
recently demonstrated that plants significantly reduced toluene and
xylene at indoor air concentrations of 768–887 µg m⁻³ (Orwell et al.,
2006) and even the TVOC concentration in office buildings during
field testing under real conditions (Wood et al., 2006). Unfortunately,
the divergences in toluene removal reported in the studies of Chen
et al. (2005) and Orwell et al. (2006) cannot be explained, especially as
the prototype used in the earlier study was not fully described. Many
parameters such as the interfacial areas, the moisture content, and the
type (hydrophobicity) of the biomass used can influence pollutant
removal in biological purifiers. There is therefore a need for a more
coordinated research in the area. Various botanical purifiers have also
been patented (i.e. US5407470, US5277877) but such devices have not
reached a broad market and no data on pollutant removal under
relevant conditions is available. Research on the development of a
commercial biological purifier has been carried out at the University of
Guelph, Canada (Darlington et al., 2000; Air Quality Solution Ltd). In
one configuration, air was purified through lava rocks covered with a
geotextile cloth supporting mosses (Darlington et al., 2001). This
device was operated at relevant influent levels equal or lower than
300 µg m⁻³ and displayed a purification efficiency of 30% at the lowest

air flow treated. Water was also added to the filter to compensate for water losses through evaporation (approx. 20 L d⁻¹ in 120 m² and 640 m³ room). In a second configuration, disclosed in US patent 6,676,091 from the same author, air is forced directly through a vertical (or slightly inclined) porous material serving as support for hydroponic plants which its main purpose is to support the activity of pollutant degrading microorganisms in the rizosphere.

From the studies herein presented, it appears that the role of plants in botanical purifier is often suspected to support a microbial activity that is responsible for pollutant removal. Direct pollutant accumulation or degradation by plants is however known to occur during phytoremediation of contaminated soils (Newman and Reynolds, 2004) and the ability of plant leaves to directly take up and remove pollutant during air treatment is still debated (Wolverton et al., 1984; Schmitz et al., 2000; Schöffner et al., 2002). A recent study has suggested that bacteria growing on plant leaves could also contribute to VOC biodegradation (Sandhu et al., 2007). More generally, there is growing evidence of the complexity, and importance of interactions between plants and bacteria (Dudler and Eberl, 2006) and research in this area is of utmost importance for IAQ. There is a lack of peer-reviewed data available in the literature and an urgent need to improve our understanding of the fundamental mechanisms of VOC uptake or release by plants and their microbial hosts (Kesselmeier and Staudt, 1999). The following discussion will therefore focus on the more established microbial degradation mechanisms.

5.1. Influence of type of VOCs

The biological treatment of organic compounds is based upon the capability of microorganisms to use these molecules as sources of carbon, nutrients and/or energy or to degrade them cometabolically using unspecific enzymes. The intrinsic biodegradability of an organic compound depends on many factors such as its hydrophobicity to the microbial population, the most soluble being generally the most biodegradable, or its toxicity. Toxicity effects, which sometimes limit the biological treatment of industrial air, are likely not a problem at the concentrations found in indoor air and this will not be discussed further in this review. Many VOCs are rather small molecules that are moderately soluble and in fact, are biodegradable (Table 4) although certain xenobiotic compounds, such as chlorinated compounds (i.e. tetrachloroethylene), may be recalcitrant. Synergetic or negative interacting effects within pollutant mixture should also be taken into consideration (Yu et al., 2001). Given the high number of VOC simultaneous found in indoor air, and the huge variations in structures and properties, a biological process suitable for indoor air treatment should rely on diverse, versatile and adaptive microbial communities to ensure all pollutants are removed. This can be achieved in fixed biofilm-based reactors where high microbial diversity and cell proximity favour cellular exchanges (Molin and Tolker-Nielsen, 2003; Singh et al., 2006), acclimation (long cell residence time) and synergetic effects under various growth conditions by the establishment of substrate concentration gradients thorough the biofilm (Beveridge et al., 1997; Marshall, 1994). Completing or combining biodegradation with a physicochemical post-treatment is also possible to ensure the complete removal of all pollutants. Finally, great variations in total and individual pollutant concentrations leading, for instance, to long periods of time when a given compound is not found in the indoor air could lead to permanent or momentary losses in catabolic ability. Such effects need to be further studied and possibly prevented as discussed below.

5.2. Influence of low concentrations on biomass productivity and transfer rates

During the biodegradation process, the concentration of an organic pollutant in the micro-environment where the microorganisms are found has a profound impact on microbial activity and ultimately on the pollutant removal rate. At reasonably high substrate concentrations, the

organic pollutant can be metabolized and used to synthesize more biomass in a process that self-regenerates the biocatalyst. When the concentration is decreased further, a critical level is reached below which new cells are no longer produced. Nevertheless, the contaminant can still be biodegraded if a significant active biomass is available and if the gene(s) responsible for the production of the enzyme(s) required for the pollutant degradation is (are) still expressed (Kovářová-Kovar and Egli, 1998). Gene expression depends, among other factors, on the concentration of the enzyme substrate which can be the pollutant or other molecules. In this context, it is crucial to compare the low concentrations at which indoor VOCs are typically found with known threshold for microbial growth and biodegradation.

Toluene indoor air concentrations of 0.58–17 µg m⁻³ have been reported in Californian office buildings (Daisey et al., 1994). Assuming toluene must first transfer into an aqueous phase before being biodegraded, the maximum aqueous toluene concentration (C_{aq}^{*}) at which microorganisms will be exposed to can be calculated from the Henry's law constant (H) coefficient:

$$C_{aq}^* = \frac{P_i}{H_i} \quad (1)$$

Where P_i is the partial pressure of the target contaminant in the gas phase and H_i its Henry constant. For toluene (H = 6.67 10⁻³ atm m³ mol⁻¹; Table 4), this will result in a C_{aq}^{*} of 2–60 ng L⁻¹ under normal conditions of temperature and pressure. If toluene is removed by 90%, microorganisms would actually be exposed to concentrations of 0.2–6 ng L⁻¹ (under continuous treatment under a steady state). At such concentration, toluene can be reasonably considered as the limiting substrate if it is the only carbon source available. By comparison, the threshold growth concentration of bacteria from drinking-water biofilm has been estimated to about 0.1 µg L⁻¹ (van der Kooij et al., 1995) which is in the same range of reported toluene mineralization at aqueous concentrations of 0.9 µg L⁻¹ with active bacteria (Roch and Alexander, 1997). Hence, from the data currently available, it seems unlikely that indoor air VOC can support growth. However, microorganisms might still be capable to use certain VOCs as energy source for maintenance or cometabolically biodegrade them by using another substrate for growth.

The specific biomass growth rate (μ, h⁻¹) at sub-inhibitory substrate concentration can often be expressed as:

$$\mu = \frac{\mu_{max} S}{K_s + S} - k_d \quad (2)$$

Where μ_{max} (h⁻¹) is the maximum specific growth rate, K_s is the saturation constant (mg L⁻¹), k_d is the endogenous decay coefficient (h⁻¹) and S is the limiting substrate concentration (mg L⁻¹). The substrate uptake volumetric rate is equivalent to:

$$r_{su} = \frac{\mu X}{Y} + mX \quad (3)$$

where X is the biomass concentration, Y is the true biomass yield (g active biomass g substrate⁻¹), and m is the maintenance coefficient. This equation shows that substrate consumption for maintenance can occur even under no growth conditions (μ_{max}S/(K_s+S) < k_d), although cell decay would cause a continuous decrease in catabolic activity.

Based on the toluene biodegradation kinetics reported by Alagappan and Cowan (2003) in *Pseudomonas putida* F1 cultures (μ_{max} = 0.37 h⁻¹ and K_s = 0.44 mg L⁻¹), the specific cell production rate under indoor conditions should range from 5 × 10⁻⁵–1.7 × 10⁻⁶ h⁻¹. These values are far below the cellular maintenance rates reported in the literature for aromatic compounds (0.019 h⁻¹ for ethylbenzene and 0.016 h⁻¹ for benzene), and the death cells coefficients for *P. putida* F1 during the degradation of toluene (0.06 h⁻¹; Alagappan and Cowan, 2003). Thus, in this particular situation, neither would pollutant supply meet maintenance requirements nor would the specific growth rate meet the cellular decay rate.

472 Although these kinetics parameters were obtained at pollutant
 473 concentrations higher than those found in indoor air, this simple
 474 calculation shows that indoor air biological treatment will likely
 475 require the development of specific methods to provide and maintain
 476 a suitable catabolic activity. First, due to the complexity and
 477 variability of indoor air, an inoculum that possesses the suitable
 478 catabolic ability might be difficult to obtain. These microorganisms
 479 would also likely need to be pre-cultivated at higher VOC concentra-
 480 tion to obtain a significant cell number in a relative short time, which
 481 might impair their ability to take up substrates at trace levels
 482 (microorganisms can lose selective traits when the corresponding
 483 selection pressure is released). Attached growth should therefore be
 484 recommended for inoculum preparation to combine, through the
 485 establishment of substrate concentration gradients inside the biofilm,
 486 microbial growth at the liquid-biofilm interface with continuous
 487 selection of microorganisms acclimated to low-substrate concentra-
 488 tion inside the biofilm (Beveridge et al., 1997). Second, maintaining
 489 catabolic activity (and not only cell mass or cellular activity) could be
 490 challenging as microorganisms can lose their ability to biodegrade
 491 certain substrates when deprived from them during long periods of
 492 time. Biofilm systems could ensure constant performance under
 493 fluctuating operating conditions by allowing substrate accumulation
 494 at the biofilm interface until degradation becomes possible (Singh
 495 et al., 2006). As mentioned above, attached microorganisms also form
 496 diverse and dynamic communities (cell communication and cellular
 497 exchanges such as horizontal gene transfer being favoured by the cell
 498 proximity) that can respond more quickly to changes, which in return
 499 favours functional redundancy (Rittmann and McCarty, 2001).
 500 Biofilms are in fact ubiquitous and prevail under diluted environment
 501 (Beveridge et al., 1997). Finally, even under conditions when suitable
 502 degradation-enzymes are expressed, microbial activity must be
 503 capable to reduce the contaminant at concentration low enough to
 504 permit significant mass transfer. Roch and Alexander (1997) showed
 505 toluene mineralization at $0.9 \mu\text{g L}^{-1}$ but the pollutant still remained at
 506 79 ng L^{-1} after 8 days of incubation. Similar findings were reported by
 507 Pahm and Alexander (1993) when studying the biodegradation of *p*-
 508 nitrophenol at trace concentration although addition of a secondary
 509 carbon source was capable to trigger pollutant removal at concentra-
 510 tions of $1 \mu\text{g L}^{-1}$. However, the feasibility of removing estrogens at
 511 100 ng L^{-1} to below 2.58 ng L^{-1} (detection limit) with pure laccase

from *T. versicolor* was recently demonstrated (Auriol et al., 2007),
 showing biological systems should be able to perform at indoor air
 concentrations.

Clearly, the development of biological methods for indoor air
 filtration faces several challenges and requires more research on the
 microbial mechanisms of acclimation, survival, substrate recognition,
 accumulation and uptake at trace concentration. Most published
 biodegradation studies have been conducted under irrelevant condi-
 tions (single substrate, high substrate concentration, suspended
 growth) using isolates cultivated in the laboratory. Current kinetics
 data might therefore underestimate the capacity of natural strains to
 take up trace pollutants (Subba-Rao et al., 1982; Pahm and Alexander,
 1993). Low concentrations are common in the environment and
 certain microorganisms have developed original survival strategies
 under such conditions by for instance accumulating limiting substrate
 before starting to growth (Singh et al., 2006). New models to correlate
 growth with substrate concentration are therefore needed at trace
 concentration, as suggested by Butterfield et al. (2002) in a study on
 drinking-water biofilm formation under carbon-limited conditions
 ($<2 \text{ mg L}^{-1}$).

The simultaneous presence of many contaminants in indoor air
 might sustain microbial growth or, at least, induce pollutant miner-
 alization, as suggested by the experience of Pahm and Alexander
 (1993) described above. Furthermore, under starving conditions,
 certain microorganisms are capable to quickly increase their affinity
 for the limiting substrates or acclimate to simultaneously mineralize
 a high number of carbon sources (Kovárová-Kovar and Egli, 1998, Tros
 et al., 1996). Particles and other air macropollutants (carbon dioxide,
 carbon monoxide, ammonia, etc) or plants might also provide enough
 energy and carbon substrates for growth, as evidenced by the
 microbial colonization of indoor surfaces and air handling systems or
 the microbial activity recorded in the rhizosphere of botanical purifier.
 In addition, certain microorganisms are able to grow both hetero-
 trophically and autotrophically (Larimer et al., 2003) or on myriads of
 different organic compounds (Chain et al., 2006). Such metabolic
 versatility would give obvious advantages under conditions where
 numerous potential carbon and energy sources are simultaneously
 found at very low concentrations and would greatly enhance the
 treatment of indoor air. The question is therefore not if microbial
 growth would occur, but if it will cause VOC reduction. For instance,

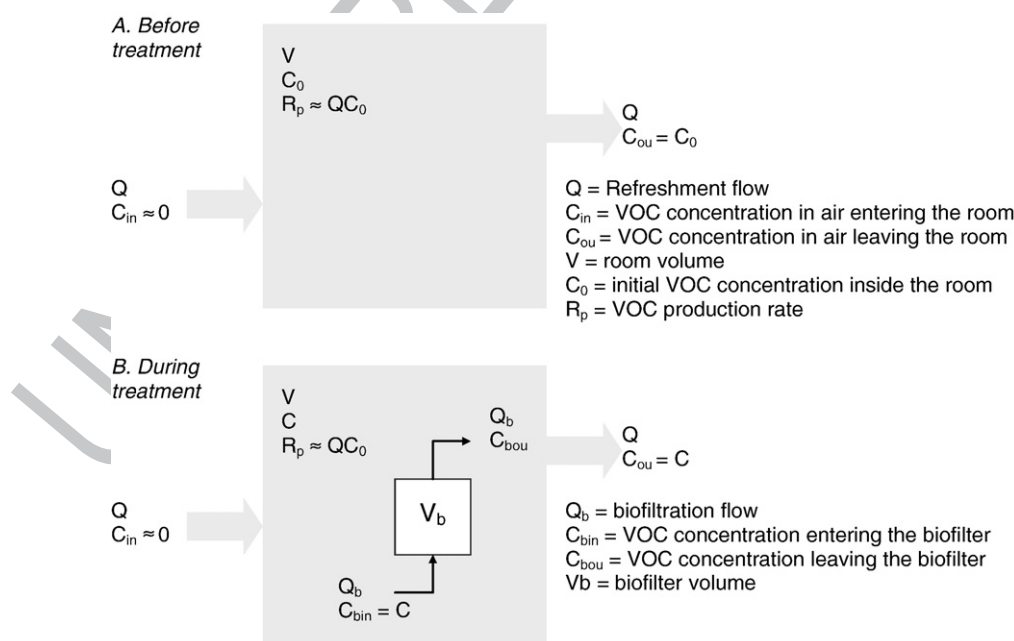

Fig. 1. Schematic presentation of a simple steady state mass balance analysis of indoor air treatment.

from field studies on the efficiency of plants to purify air from office buildings, Wood et al. (2006) suggested that a TVOC concentration of 100 ppb was sufficient to induce a biological response that could reduce the TVOC concentration up to 75%. In addition, during laboratory studies on VOC removal by potted plants in sealed chamber, Orwell et al. (2006) observed the presence of toluene accelerated the removal of *x*-xylene, although the reciprocal was not true.

Several authors have also challenged the mass transfer and microbial uptake theories use to predict the effect of substrate concentration in biological purifiers. Active transfer by enzymatic transformation has for instance been reported and mechanisms of direct uptake at the air-cell interface have been suggested. For instance, Miller and Allen (2005) reported that direct pollutant diffusion through the aqueous layer surrounding the biofilm could not explain the surprisingly high performances of biological systems treating the highly hydrophobic alpha-pinene. Likewise, it has been suggested that the aerial mycelia of fungi, which are in direct contact with the gas phase, might promote the direct uptake of VOC from the gas phase. This uptake is faster than if a flat biofilm of bacteria directly contacts the gas phase because of a high gas-mycelium interfacial area of the fungal mat and the highly hydrophobic nature of the fungal cell wall (Arriaga and Revah, 2005; Kennes and Veiga, 2004; Van Groenestijn and Kraakman, 2005, Vergara et al., 2006).

5.3. Impact of purification efficiency on design

A simple steady state mass balance analysis can be used to design a device for indoor air purification (Fig. 1) based on the following equation:

$$V \frac{dC}{dt} = QC_{in} - QC_{out} + R_p \quad (4)$$

where V is the room volume (m^3); C the TVOC concentration in the room ($\mu g m^{-3}$); Q is the refreshment flow rate ($m^3 h^{-1}$) through the room, C_{in} is the TVOC concentration of the air entering the room ($\mu g m^{-3}$), C_{out} is the TVOC concentration of the air leaving the room ($\mu g m^{-3}$), and the R_p is the TVOC production rate inside the room ($\mu g h^{-1}$).

At steady state under completely mixed conditions within the control volume analyzed $dC/dt=0$ and $C=C_{out}$. Assuming that C_{in} is negligible compared to C_{out} (indoor air concentrations are usually higher than outdoor), Eq. (5) gives:

$$R_p = QC_0 \quad (5)$$

where $C_0=C_{out}$ represents the initial pollutant concentration in the room, before air is being cleaned. When an air treatment unit (i.e. a biological purifier) is started in the room the mass balance analysis becomes:

$$V \frac{dC}{dt} = QC_{in} - QC_{out} + R_p - R_b \quad (6)$$

Where, for a biological purifier, R_b is the TVOC biological removal rate ($\mu g h^{-1}$).

If we assume that R_p is constant (which is unlikely as the rate of VOC evaporation from coatings depends on the concentration of the VOC in the room and the concentration in the material) and $C_{in} \approx 0$, the rate of TVOC biologically removed under steady state conditions can be expressed as:

$$R_b = Q(C_0 - C) \quad (7)$$

If we now consider the biological purifier, R_b can also be expressed as:

$$R_b = Q_b(C_{bin} - C_{bout}) \quad (8)$$

Where C_{bin} and C_{bout} are the TVOC concentration in the air entering and leaving the biological purifier, respectively; and Q_b is the air flow treated by the biological filter.

By definition, the single pass efficiency (%) of the biological purifier is expressed as:

$$\eta = \frac{C_{bin} - C_{bout}}{C_{bin}} \quad (9)$$

Based on the assumption of completely mixed conditions in the room $C_{bin} = C$, then:

$$R_b = \eta C Q_b \quad (10)$$

Combining Eqs. (8) and (11) gives the following expression for Q_b :

$$Q_b = \frac{C_0 - C}{\eta C} Q \quad (11)$$

The required biological purifier air flow is therefore a function of the single pass biofiltration efficiency, the initial and required TVOC concentrations, and the refreshment rate. It can also be expressed as a function of the ratio between initial and final concentrations in the room ($A=C_0/C$), which is another expression of the removal efficiency according to:

$$Q_b = \frac{A-1}{\eta} Q \quad (12)$$

The overall performance of the purification device can then be expressed as its effectiveness (R , %) according to:

$$R = \frac{C_0 - C}{C_0} \quad (13)$$

Based on this equation, a simulation was made to determine Q_b under varying R and η values at $C_0=500 \mu g m^{-3}$ (Fig. 2) as typical TVOC values in sick houses range from 100 to 1000 $\mu g m^{-3}$. The refreshment rate was assumed to 0.35 h^{-1} in a room of 100 m^3 ($Q=35 m^3 h^{-1}$) as described by Volkoff et al. (1991). This simulation shows that a purification flow (Q_b) of approx. 400 $m^3 h^{-1}$ is required to achieve a satisfactory overall purification effectiveness of 90% with $\eta=80\%$. This is rather logical since the removal efficiency of any system is intrinsically limited by the low concentration of the pollutants. These values are in accordance with the recommended air cleaner true effectiveness of 80% for particle removal, which is equivalent to providing 4-5 room volumes of clean air per hour (Shaughnessy and Sextro, 2006). Hence, it is not only the single pass purification efficiency of the biofiltration device but the overall purification capacity (ηQ_b) that is important, explaining why the concept of Clean Air Delivery Rate ($CADR=\eta Q_b$, the amount of purified air delivered per unit or time) was introduced to evaluate and compare the various devices proposed for air removal (Shaughnessy and Sextro, 2006). Interestingly, at equivalent CADR, purification devices with high single pass efficiencies should be preferred because of their lower energy requirement (lower required flow rate).

The biological purifier can be designed using another engineering approach based on the gas residence time (t_{res}) in the purifier and the purifier refreshment capacity (α):

$$t_{res} = \frac{V_b}{Q_b} \quad (14)$$

where V_b is the volume of the biological purifier.

$$\alpha = \frac{\eta \cdot Q_b}{V} = \frac{CADR}{V} \quad (15)$$

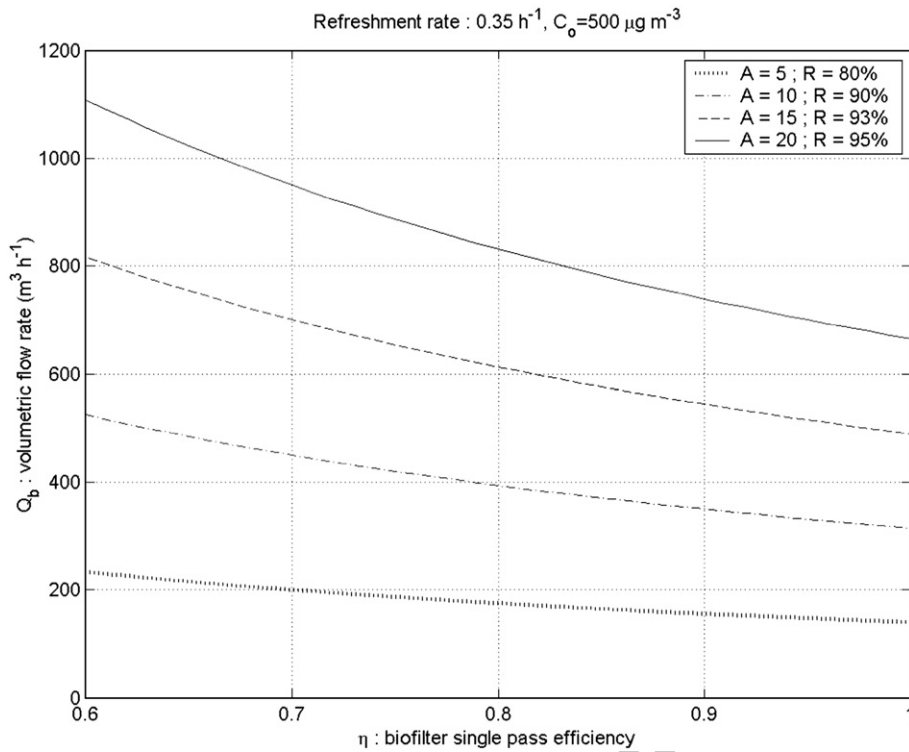

Fig. 2. Simulated performance of the effect of the biological purifier single pass efficiency (η , %) on the required biofiltration volumetric flow rate (Q_b , $m^3 h^{-1}$) to achieve an overall effectiveness $R=80-95\%$ (with $R=(C_0-C)/C_0$ where C and $C_0=500 \mu g m^{-3}$ are the steady state TVOCs concentrations before and during the biological purifier operation, respectively) in a $100 m^3$ room with a refreshment rate of $0.35 h^{-1}$. The air cleaner effectiveness can also be expressed as the ratio $A=C/C_0$.

Thus, the biological purifier volume required can be expressed as:

$$(17) V_b = \frac{\alpha \cdot t_{res} \cdot V}{\eta}$$

Assuming a typical gas residence time (industrial applications) of 30 s, a purifier refreshment capacity of $4 h^{-1}$, and a 80% single pass efficiency, the biological purifier volume required for a $100 m^3$ room would be $4.2 m^3$, which is a prohibitive volume in indoor environment. Even at such a short residence time as 2 s, the volume of the bioreactor needed in our simulation would be 278 L. By comparison, the biological purifier developed by Darlington et al. (2001) was tested at surface loading rates of $90-720 m^3 m^{-2} h^{-1}$, which is within the range of operation of industrial biotrickling filter and bioscrubbers ($100-1000 m^3 m^{-2} h^{-1}$; Van Groenestijn and Hesselink, 1993). The 1920 L ($9.6 m^2$) bioscrubber (not including plants and aquarium used for water circulation) was also operated in a $640 m^3$ room at influent toluene, ethylbenzene and xylene concentrations of $0-300 \mu g m^{-3}$. Single pass efficiencies of approx. 10-30% were achieved depending on the flow (the higher the flow, the lower the single pass efficiency) and temperature, which accounted for a CADR of $720 m^3 h^{-1}$ equivalent to a refreshment rate of $1.1 h^{-1}$. Although it is difficult to draw conclusions from this single study, the data provided seems consistent with our simulation. It clearly shows that the engineering of compact biological purifiers with high effectiveness will be an important challenge.

The model described above can also be used to simulate the dynamic changes in pollutant concentration in a room where air purification is started by using Eq. (4) expressed as:

$$V \frac{dC}{dt} = QC_0 - QC - \eta Q_b C \tag{16}$$

Which can then be integrated as:

$$C_t = C_0 \exp(-Bt) + \frac{A}{B} (1 - \exp(-Bt)) \tag{17}$$

With

$$B = \frac{Q + \eta Q_b}{V} = \frac{Q + CADR}{V} \tag{18}$$

And

$$A = \frac{QC_0}{V} \tag{19}$$

In Eq. (17), $C_0 \exp(-Bt)$ represents the combined VOC removal from refreshment and biofiltration and $\frac{A}{B} (1 - \exp(-Bt))$ represents the production within the room. Using the example described above ($V=100 m^3$, $Q=35 m^3 h^{-1}$, $C_0=500 \mu g m^{-3}$), Fig. 3 shows that at the range of purification flows required for such application, steady states conditions are achieved rather quickly (1-2 h). Similar models are used to estimate the single pass efficiency of purification devices in sealed chamber test where pollutant are introduced at a certain amount but where there is no production (Chen et al., 2005). Thus, Wolverton et al. (1989) reported a decreased in benzene concentration from 765 to $78 \mu g m^{-3}$ in 24 h in a sealed chamber containing a plant, which resulted in a B coefficient in Eq. (18) of $0.1 h^{-1}$. The B coefficient is composed of the pollutant leakage rate from the system (Q/V) and the pollutant removal in the air purifier ($CADR/V$ =purifier refreshment capacity). The same author conducted a leak experiment which allowed calculating the leak contribution to approx. $0.01 h^{-1}$. Hence, the botanical purifier used in this study generated an amount of purified air equivalent to 0.09 room volume per hour (CADR of $0.075 m^3 h^{-1}$) and would not significantly improve IAQ under realistic conditions. Low refreshment rates of $0.02-0.3 h^{-1}$ were also achieved by Orwell et al. (2006) in sealed chambers containing potted plants and initially supplied with $768-886 \mu g m^{-3}$ of *m*-xylene or toluene based on VOC exponential removal rate constants of $0.52-7.44 d^{-1}$. Likewise, Chen et al. (2006) achieved the highest CADR of $8.3 m^3 h^{-1}$ (refreshment rate of $0.15 h^{-1}$) with the botanical purifier compared to

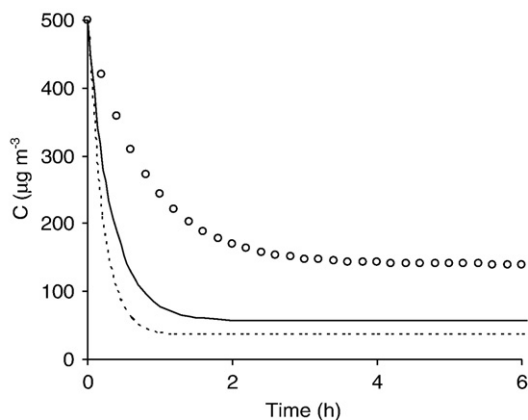

Fig. 3. Simulated changes in TVOC concentration (C , $\mu\text{g m}^{-3}$) in a 100 m^3 room where air purification is started at $t=0$ at a flow of 500 (dashed line), 300 (plain line) or 100 (circles) $\text{m}^3\text{ h}^{-1}$ in a biological purifier with 90% single pass efficiency. The refreshment rate in the room is 0.35 h^{-1} and the initial TVOC concentration is $500\text{ }\mu\text{g m}^{-3}$.

values above $200\text{ m}^3\text{ h}^{-1}$ with other portable devices. Despite this, a significant TVOC removal was recorded when using potted plants during field testing in office (Wood et al., 2006) and even if such results should be reproduced under better controlled conditions, they might indicate that our current evaluation models are inadequate.

5.4. Humidification and biohazards

Since biological purifiers are typically saturated with water and since indoor air treatment requires high flows, indoor biological purification might increase the moisture content in the room or building where it is used. This beneficial effect when indoor air is too dry (moisture contents of 30–60% are generally recommended for comfort) could also trigger to the excessive growth of fungi with negative impact on IAQ (Schleibinger et al., 2004), although these effects are still uncertain (Robbins et al., 2000; Pasanen, 2001). Darlington et al. (2000) for instance reported that the use of an indoor biological purifier significantly increased the concentrations of total suspended spores, although these values were similar to concentrations found in flats containing house plants, and still remained within healthy levels ($100\text{--}200\text{ CFU m}^{-3}$). In addition, none of the 17 fungal species identified was known pathogenic. Likewise, Ottengraf and Konings (1991) reported that the concentration of microbial germs (mainly bacteria) in the outlet of full scale industrial biofilters was within the range of typical indoor air concentration, and only slightly higher than typical outdoor air concentrations, which was more recently confirmed by Zilli et al. (2005). There is however too little data available and the potential release of microorganisms from indoor biological purifiers (especially in the case of faulty equipment or accidents) should be better studied and prevented if necessary.

5.5. Esthetic, noise, purification perception

Besides being efficient for pollutant removal, indoor air purifiers must be esthetic (unless it is integrated into the ventilation system) and silent, which is rather challenging considering the flow required and the volumetric constrains. As mentioned above, indoor air pollution involves many types of pollutants (particulates, inorganic etc), which concentrations must all be reduced below a certain “perception” level for users to feel the improvement of air quality. Especially, the effects of macropollutants such as CO_2 and H_2O should also be considered.

5.6. Evaluating performance

Setting-up realistic purification goals is difficult as there are only few guidelines on indoor VOC concentration. Evaluating performance

is no less challenging due to the analytical difficulty to detect numerous substances at very low concentrations, the lack of knowledge about contaminants and their effects, and because of the number of associated effects of air purification (i.e. moisture, temperature, physiological impacts on user). Ultimately, blind testing in sick buildings that could correlate pollutant removal with customer/user satisfaction (by survey, measurement of productivity, etc) and health improvements would be necessary. Unfortunately, such methods cannot be used during phases of design and optimization for economical reasons and because of the need for well-defined and reproducible testing conditions, replicate and control. Hence, the efficiency of air purifiers is generally evaluated by either direct measuring of the single pass efficiency or by using test-chambers. In the first case, an artificially contaminated air stream is passed at a certain flow through the purification device and the concentrations of the target contaminants are measured at the inlet and outlet of the purifier (Howard-Reed et al., 2002). This method is rather simple and the influence of parameters such as the effluent composition or the treatment flow can easily be tested under continuous inlet air composition. Test-chamber assays are however often preferred, perhaps because they offer more flexibility and better simulate the indoor environment. Here, pollutants are injected in a hermetical chamber equipped with the air purifier as well as various sampling, analysis, and air conditioning devices and their concentrations are measured over time. The purifier efficiency can then be evaluated using the basic model described above. Depending on the size and complexity of the chamber, the pollutant can be replaced by polluting-material and treatment efficiency can be evaluated, for instance, in terms of work productivity by monitoring the activity of human test-workers operating inside the chamber (Wargocki et al., 1999). The use of artificially contaminated air also brings its own challenges as it is very difficult to determine a universal “model indoor air” due to the diversity and variability of pollutants concerned (Ekberg, 1994; Yu and Crump, 1998; Otson et al., 1994). However, recent progresses have been made in that direction (Ondarts et al., 2007).

VOC analysis from indoor air normally requires large air samples that are passed through a solid or liquid absorbent that serves to concentrate the contaminants, followed by further extraction/separation and analysis (Crump, 2001). However, many pollutants are not known or cannot be detected at indoor air concentration levels (Ondarts et al., 2007) and the costs of monitoring all known compounds would be prohibitive. In such cases, the TVOC (for details on protocols see Crump, 2001) can be measured although this parameter can be exclusive and does not take into consideration the different intrinsic toxicities of each compounds and interaction effects between the pollutants (Wolkoff, 2003; Wolkoff and Nielsen, 2001; Molhave, 2003).

6. Designing biological purifiers

Common biological processes for VOCs abatement include bioscrubbers, biotrickling filter, and biofilters (Iranpour et al., 2005; Burgess et al., 2001; Delhoméie and Heitz, 2005; Revah and Morgan-Sagastume, 2005). In bioscrubbers, the air is washed with an aqueous phase into which the pollutants transfer, and the aqueous phase is transferred into a bioreactor where the pollutants are biodegraded. In biotrickling filters, microorganisms are grown on an inert material (plastics resins, ceramics etc). An aqueous solution containing the nutrients required for microbial growth is continuously distributed and recirculated at the top of the reactor and percolates by gravity, thus covering the biofilm with an aqueous layer. Contaminated air is introduced as co- or counter current and the contaminants diffuse into the aqueous phase where they are biodegraded. The purpose of the packing material is to facilitate the gas and liquid flows and enhance gas/liquid contact, to offer a surface for microbial growth, and to resist crushing and compaction. In biofilters, air is passed through a moist

porous material which supports microbial growth. Water remains within the packing material and is added intermittently to maintain humidity and microbial viability. The packing material is generally a natural material (peat, compost, wood shavings, etc.) which is biodegradable and provides nutrients to the microorganisms although intensive research has been done to use synthetic materials (Jin et al., 2006).

Because they provide large interfacial areas for exchange, biofilters are typically recommended for low-substrate concentrations and poorly soluble substances. On the other hand, biotrickling filters and bioscrubbers allow higher surface volumetric loading rates and are more suitable for conditions of fast transfer (high pollutant concentration) or when pH needs to be controlled. As indoor air biofiltration implies low transfer and high volumetric flow, it is not clear which of the configurations described above will be the best. However, biofilm-based technologies offer many advantages in regards of the microbial properties required and the utilization of a biodegradable (i.e. compost) or bioactive (i.e. soil, plants roots, plant leaves) support for growth might allow microbial activity at low-substrate concentration. It is therefore not surprising that botanical purifiers, which are based on configurations taking advantage of air exchange through the plant root-soil or plant-foilage areas, have been more extensively studied for indoor air purification so far.

Emerging technologies could provide a more suitable platform for indoor air biological purification. Biological indoor air treatment can potentially release dust, microorganisms, and water. These problems can be simultaneously solved by using membrane bioreactors which physically disconnect the sorption step (air-water exchange) from the biodegradation step. The use of membrane bioreactors for VOC removal is nowadays only established at high pollutant loads (Ergas et al., 1999) but recent studies have demonstrated that such systems could be efficient at indoor air concentration levels (Llewellyn and Dixon, 2006, Ramis et al., 2007). The use of membrane could allow more compact designs for indoor air treatment. This is clearly a very promising technology which should be further investigated.

An additional common limitation to all biological air treatment processes is the need to transfer contaminants into an aqueous phase prior to their biodegradation, which is especially problematic in the case of hydrophobic pollutants such as hexane. The addition of a hydrophobic organic phase into the bioreactors (two liquid phase partitioning bioreactors) could significantly enhance the transfer of the pollutants to the microorganisms and thereby, their removal (Muñoz et al., 2007). Other possibilities include the addition of activated carbon or other adsorbents in combination with the biological system. Such approaches should be investigated in the case of indoor air treatment as they could also concentrate the contaminants to levels suitable for growth.

7. Conclusions

Poor indoor air quality is a worldwide problem with tremendous human health and economical consequences. Although technologies for particle removal are rather well established, there are nowadays no satisfactory methods for VOC control because removing indoor VOC sources or increasing ventilation rates is often not feasible or economical. There is a therefore a need for designing specific air purifying devices to clean and circulate the air inside affected buildings. Among the technology potentially suitable for this purpose are biological systems replying upon the ability of plants and/or organisms to detoxify organic compounds. However, a critical review of the existing literature in regards to biological and engineering constrains reveals numerous problems that must be solved before biologically-based air purifiers can be designed and implemented.

First, our current knowledge on microbial kinetics and the thresholds for substrate uptake, consumption and gene expression raise serious doubt concerning the feasibility of microbial degradation of VOCs at indoor air concentrations. Yet, we also know biological systems (in a

broad sense) respond to indoor VOCs because of the linkages between VOC occurrence and SBS. In addition, there is experimental evidence that VOCs can be biologically removed at indoor concentration even if the precise mechanisms are unknown. This apparent contradiction is perhaps explained by the fact that our current knowledge was derived from studies conducted under conditions (single strains with single substrate at high concentration) irrelevant to the indoor air environment (diverse communities exposed to multiple substrates at low concentrations and direct pollutant uptake). Clearly, there is a need for fundamental research under indoor relevant conditions. This would not only help to design and optimize indoor air biological purifiers but also to solve growing environmental issues linked to trace contaminants in water resources. One of the most interesting areas of research is perhaps the study of heterotroph-phototroph relationships such as those observed in plants. This could explain why plants "appear" to remove VOC at trace concentration when this hardly benefit them (from a detoxification point of view) and why microorganisms could degrade indoor VOCs and survive starvation.

Second, the design of biological air purifier requires the development of new technologies for highly efficient pollutant transfer (from air to the biological catalyst) in order to allow high volumetric treatment flows while maintaining high treatment efficiencies. Current biological purifiers have shown some potential but are all limited by their low treatment capacity. Solutions could be found among technologies (i.e. membrane bioreactors) that liberate from the need to transfer VOC to an aqueous phase. This opens interesting possibilities for cross-disciplinary research initiatives.

Finally, as IAQ is linked to the presence of pollutants other than VOC and as biological methods might always be limited in the cases of poorly soluble or recalcitrant substances, there is a need to develop combined physicochemical-biological methods. This is especially necessary to eliminate potential nuisances from the biological purifier itself.

8. Uncited references

US EPA

US Green Building Council

Acknowledgments

The "Université de Pau et de Pays de l'Adour" is gratefully acknowledged for supporting the visit of Dr Guieysse at its "Laboratoire de Thermique, Energétique et Procédés". We finally would like to thank supports from the French-Mexican exchange program PCP 07-05 "Evaluation of biofiltration supports for indoor air purification" (*Etude des performances d'un nouveau support de biofiltration appliqué à la dépollution de l'air intérieur*) and from the Spanish Ministry of Education and Science (RYC-2007-01667 contracts).

References

- Aguado S, Polo AC, Bernal MP, Coronas J, Santamaria J. Removal of pollutants from indoor air using zeolite membranes. *J. Membr. Sci.* 2004;240:159-66.
- Alagappan G, Cowan R. Substrate inhibition kinetics for toluene and benzene degrading pure cultures and a method for collection and analysis of respirometric data for strongly inhibited cultures. *Biotechnol. Bioeng.* 2003;83:798-810.
- Andersson K, Bakke JV, Bjørseth O, Børneshag CG, Clausen G, Hongso JK, et al. TVOC and health in non-industrial indoor environments. *Indoor Air* 1997;7:78-91.
- Air Quality Solution Ltd. www.naturaire.com
- Arriaga S, Revah S. Improving hexane removal by enhancing fungal development in a microbial consortium biofilter. *Biotechnol. Bioeng.* 2005;90:107-15.
- Auriol M, Filali-Meknassi Y, Tyagi RD, Adams CD. Laccase-catalyzed conversion of natural and synthetic hormones from a municipal waster. *Water Res.* 2007;41:3281-8.
- Ayoko GA. Volatile organic compounds in indoor environments. In: Hutzinger O, editor. *The handbook of environmental chemistry.* Springer-Verlag; 2004. p. 1-35.
- Beveridge TJ, Makin SA, Kadurugamuwa JL, Li Z. Interaction between biofilms and the environment. *FEMS Microbiol. Rev.* 1997;20:291-303.
- Brown VM, Crump DR. Volatile organic compounds. In: Berry et al RW, editor. *Indoor air establishment.* Watford, Herts: Indoor Environment Ltd; 1996.
- Brunekreef B, Houthuijs D, Dijkstra L, Boleij JS. Indoor nitrogen dioxide exposure and children's pulmonary function. *J. Air Waste Manage. Assoc.* 1990;40:1252-6.

- Burge PS. Sick building syndrome. *Occup. Environ. Med.* 2004;61:185–90.
- Burgess JE, Parsons SA, Stuetz RM. Developments in odour control and waste gas treatment biotechnology: a review. *Biotechnol. Adv.* 2001;19:35–63.
- Butterfield PW, Camper AK, Ellis BD, Jones WL. Chlorination of model drinking water biofilm: implications for growth and organic carbon removal. *Water Res.* 2002;36:4391–405.
- Canada MdAeS. Directives d'exposition concernant la qualité de l'air des résidences. Rapport du Comité consultatif fédéral-provincial de l'hygiène du milieu et du travail. Canada: Ottawa, Ministère des Approvisionnement et Services; 1987. p. 1–31.
- Carlsson H, Nilsson U, Ostman C. Video display units: an emission source of the contact allergenic flame retardant triphenyl phosphate in the indoor environment. *Environ. Sci. Technol.* 2000;34:3885–9.
- Chain PSG, Denev VJ, Konstantinidis KT, Vergez LM, Agullo L, et al. *Burkholderia xenovorans* LB400 harbors a multi-replicon, 9.73-Mbp genome shaped for versatility. *PNAS* 2006;103:15280–7.
- Chen W, Zhang JS, Zhang Z. Performance of air cleaners for removing multiple volatile organic compounds in indoor air. *ASHRAE Trans.* 2005;111:1101–14.
- Crump D. Strategies and protocols for indoor air monitoring of pollutants. *Indoor Built Environ.* 2001;10:125–31.
- Daisey JM, Hodgson AT, Fisk WJ, Mendell MJ, Ten Brinke J. Volatile organic compounds in twelve Californian office buildings: classes, concentrations and sources. *Atmos. Environ.* 1994;28:3557–62.
- Darlington A, Chan M, Malloch D, Pilger C, Dixon MA. The biofiltration of indoor air: implications for air quality. *Indoor Air* 2000;10:39–46.
- Darlington AB, Dat JF, Dixon MA. The biofiltration of indoor air: air flux and temperature influences the removal of toluene, ethylbenzene, and xylene. *Environ. Sci. Technol.* 2001;35:240–6.
- Darlington AB. An integrated indoor air biofiltration system for municipal infrastructure. University of Guelph; 2004. p. 1–50.
- Delhoménie MC, Heitz M. Biofiltration of air: a review. *Crit. Rev. Biotechnol.* 2005;25:53–72.
- Devanny JS, Deshusses MA, Webster TS. Biofiltration for air pollution control. Boca Raton: Lewis Publishers; 1999.
- Dudler R, Eberl L. Interactions between bacteria and eukaryotes via small molecules. *Curr. Opin. Biotech.* 2006;17:268–73.
- Edwards RD, Jurvelin J, Koistinen K, Saarela K, Jantunen M. VOC identification from personal and residential indoor, outdoor and workspace microenvironment samples in EXPOLIS-Helsinki. *Finland Atmos. Environ.* 2001;35:4829–41.
- Ekberg LA. Volatile organic compounds in office buildings. *Atmos. Environ.* 1994;28:3571–5.
- Ergas SJ, Schroeger ED, Chang DPY. Biodegradation technology for volatile organic compound removal from airstream. Final report. Contract No. A032-127. California Environmental Protection Agency, Air Resources Board, Research Division; 1992. May.
- Ergas SJ, Shumway L, Fitch MW, Neemann JJ. Membrane process for biological treatment of contaminated gas streams. *Biotechnol. Bioeng.* 1999;63:431–41.
- Fisk WJ. Health and productivity gains from better indoor environments and their relationship with building energy efficiency. *Annu. Rev. Energy Environ.* 2000;25:537–66.
- Howard-Reed C, Nabinger SJ, Emmerich SJ. Measurement and simulation of the indoor air quality impact of gaseous air cleaners in a test house. 9th International Conference on Indoor Air Quality and Climate. Proceedings, vol. 2. *Indoor Air*; 2002. p. 652–7.
- Hudnell HK, Otto DA, House DE, Mølhave L. Exposure of humans to a volatile organic mixture II. Sensory. *Arch. Environ. Health* 1992;47:31–8.
- Iranpour R, Cox HHJ, Deshusses MA, Schroeder ED. Literature review of air pollution control biofilters and biotrickling filters for odor and volatile compound removal. *Environ. Prog.* 2005;24:254–67.
- Jin Y, Veiga MC, Kennes C. Development of a novel monolith-bioreactor for the treatment of VOC-polluted air. *Environ. Technol.* 2006;27:1271–7.
- Johnston PK, Hadwen G, McCarthy J, Girmann JR. A screening-level ranking of toxic chemicals at levels typically found in indoor air. *US-EPA* 2002;930–6.
- Jones AP. Indoor air quality and health. *Atmos. Environ.* 1999;33:4535–64.
- Kennes C, Veiga MC. Fungal biocatalysts in the biofiltration of VOC-polluted air. *J. Biotechnol.* 2004;113:305–19.
- Kesselmeier J, Staudt M. Biogenic volatile organic compounds (VOC): an overview on emission, physiology and ecology. *J. Atmos. Chem.* 1999;33:23–88.
- Kostiainen R. Volatile organic compounds in the indoor air of normal and sick houses. *Atmos. Environ.* 1995;29:693–702.
- Kovárová-Kovar K, Egli T. Growth kinetics of suspended microbial cells: from single-substrate-controlled growth to mixed-substrate kinetics. *Microbiol. Mol. Biol. Rev.* 1998;62:646–66.
- Larimer FW, Chain P, Hauser L, Lamerdin J, Malfatti S, Do L, et al. Complete genome sequence of the metabolically versatile photosynthetic bacterium *Rhodospirillum rubrum*. *Nat. Biotechnol.* 2003;22:55–61.
- Llewellyn D, Dixon MA. Botanical-membrane hybrid for the biofiltration of indoor air. Proceedings of the USC-TRG Conference on Biofiltration for Air Pollution Control, Long Beach, California; 2006. p. 5–84.
- Lomborj B. The skeptical environmentalist. Cambridge: Cambridge University Press; 2002. p. 182.
- MacLeod CT, Daugulis AJ. Biodegradation of polycyclic aromatic hydrocarbons in a two-phase partitioning bioreactor in the presence of a bioavailable solvent. *Appl. Microbiol. Biotechnol.* 2003;62:291–6.
- Market report: indoor air quality. *Filtration Industry Analyst.* 2004. p.14.
- Marshall KC. Microbial adhesion in biotechnological processes. *Curr. Opin. Biotechnol.* 1994;5:296–301.
- Miekisch W, Schubert JK, Noeldge-Schomburg GFE. Diagnostic potential of breath analysis – focus on volatile organic compounds. *Clin. Chim. Acta* 2004;347:25–39.
- Miller MJ, Allen DG. Modeling transport and degradation of hydrophobic pollutants in biofilters. *Chem. Eng. J.* 2005;113:197–204.
- Mohd AI, Hiroyasu M, Yoshimasa Y, Kimitoshi F, Katsumi N. Removal of mixtures of acetaldehyde and propionaldehyde from waste gas in packed column with immobilized activated sludge gel beads. *Biochem. Eng. J.* 2001;8:9–18.
- Mølhave L. Organic compounds as indicators of air pollution. *Indoor Air* 2003;13:12–9.
- Molin S, Tolker-Nielsen T. Gene transfer occurs with enhanced efficiency in biofilms and induces enhanced stabilisation of the biofilm structure. *Curr. Opin. Biotechnol.* 2003;14:255–61.
- Mosqueron L, Nedellec V. Hiérarchisation sanitaire des paramètres mesurés dans les bâtiments par l'observatoire de la qualité de l'air intérieur. *Observatoire de la Qualité de l'Air Intérieur*; 2002. p. 2–98.
- Mosqueron L, Nedellec V. Revue des enquêtes sur la qualité de l'air intérieur dans les logements en Europe et aux Etats-Unis. *Observatoire de la qualité de l'air intérieur*; 2004. p. 1–55.
- Muir DCG, Howard PH. Are there other persistent organic pollutants? *Environ. Sci. Technol.* 2006;40:7157–66.
- Muñoz R, Villaverde S, Guieysse B, Revah S. Two phase partitioning bioreactors for the treatment of volatile organic compounds. *Biotechnol. Adv.* 2007;25:410–22.
- Newman LA, Reynolds CM. Phytodegradation of organic compounds. *Curr. Opin. Biotechnol.* 2004;15:225–30.
- OQAI (Observatoire de la Qualité de l'Air Intérieur). <http://www.air-interieur.org/>
- Ondarts M, Platel V, Hort C, Sochard S. Evaluation of indoor air treatment by two pilot-scale biofilters packed with compost and compost-based material. Proceedings of the 15th International Conference on Air Pollution 2007: Modelling, Monitoring and Management of Air Pollution. Algarve, Portugal; 2007.
- Orwell RL, Wood RL, Tarran WJ, Torpy F, Burchett MD. Removal of benzene by the indoor plant/substrate microcosm and implications for air quality. *Water Air Soil Pollut.* 2004;157:193–207.
- Orwell RL, Wood RA, Burchett MA, Tarran J, Torpy F. The potted-plant microcosm substantially reduces indoor air VOC pollution: II. Laboratory study. *Water Air Soil Pollut.* 2006;177:59–80.
- Otake T, Yoshinaga J, Yanagisawa Y. Analysis of organic esters of plasticizer in indoor air by GC-MS and GC-FPD. *Environ. Sci. Technol.* 2001;35:3099–102.
- Otson R, Fellin P, Tran Q. VOCs in representative Canadian residences. *Atmos. Environ.* 1994;28:3563356–9.
- Ottengraf SPP, Konings JHG. Emission of microorganisms from biofilters. *Bioprocess Eng.* 1991;7:89–96.
- Palm MA, Alexander M. Selecting inocula for the biodegradation of organic compounds at low concentration. *Microb. Ecol.* 1993;25:275–86.
- Parvatyiar MG, Govind R, Bishop DF. Treatment of trichloroethylene (TCE) in a membrane biofilter. *Biotechnol. Bioeng.* 1996;50:57–64.
- Pasanen AL. A review: fungal exposure assessment in indoor environments. *Indoor Air* 2001;11:87–98.
- Phillips M. Method for the collection and assay of volatile organic compounds in breath. *Anal. Biochem.* 1997;247:272–8.
- Pilotto LS, Douglas RM, Attewell RG, Wilson SR. Respiratory effects associated with indoor nitrogen dioxide exposure in children. *Int. J. Epidemiol.* 1997;26:788–96.
- Ramis A, Hort C, Sochard S, Platel V. Treatment of the confined air of a spacecraft cabin biotechniques for air pollution control. International Congress for Air Pollution Control, A Coruna, Spain 3–5 October; 2007. p. 323–73.
- Revah S, Morgan-Sagastume JM. Methods for odor and VOC control. In: Shareefdeen Z, Singh A, editors. *Biotechnology for odour and air pollution*. Heidelberg: Springer-Verlag; 2005. p. 29–64.
- Rittmann BE, McCarty PL. *Environmental biotechnology: principles and applications*. Mc-Graw Hill; 2001.
- Robbins CA, Swenson LJ, Nealley ML, Gots RE, Kelman BJ. Health effects of mycotoxins in indoor air: a critical review. *Appl. Occup. Environ. Hyg.* 2000;15:773–84.
- Roch F, Alexander M. Inability of bacteria to degrade low concentrations of toluene in water. *Environ. Toxicol. Chem.* 1997;16:1377–83.
- Rodes C, Kamens R, Wiener RW. The significance and characteristics of the personal activity cloud on exposure assessment measurements for indoor contaminants. *Indoor Air* 1991;1:123–45.
- Sakai K, Norbäck D, Mi Y, Shibata E, Kamijima M, Yamada T, et al. A comparison of indoor air pollutants in Japan and Sweden: formaldehyde, nitrogen dioxide, and chlorinated volatile organic compounds. *Environ. Res.* 2004;94:75–85.
- Salthammer T. Emission of volatile organic compounds from furniture coatings. *Indoor Air* 1997;7:189–97.
- Samet JM, Lambert WE, Skipper BJ, Cushing AH, Hunt WC, et al. Nitrogen dioxide and respiratory illnesses in infants. *Am. Rev. Respir. Dis.* 1993;148:1258–65.
- Sander R. Compilation of Henry's law constants for inorganic and organic species of potential importance in environmental chemistry; 1999. <http://www.mpch-mainz.mpg.de/~sander/res/henry.html>.
- Sandhu A, Halverson LJ, Beattie GA. Bacterial degradation of airborne phenol in the phyllosphere. *Environ. Microbiol.* 2007;9:383–92.
- Schäffner A, Messner B, Langebartels C, Sandermann H. Genes and enzymes for in-plant phyto-remediation of air, water and soil. *Acta Biotechnol.* 2002;22:141–52.
- Schleibinger H, Keller R, Rüdén H. Indoor air pollution by microorganisms and their metabolites. In: Pluschke P, editor. *The handbook of environmental chemistry*, vol. 4. Berlin Heidelberg: Springer-Verlag; 2004. p. 149–77. Part F.
- Schmitz H, Hilger U, Weinder M. Assimilation and metabolism of formaldehyde by leaves appear unlikely to be of value for indoor air purification. *New Phytol.* 2000;147:307–15.
- Shareefdeen Z, Singh A. *Biotechnology for odor and air pollution control*. Heidelberg: Springer-Verlag; 2005.

- 1129 Shaughnessy RJ, Levetin E, Blocker J, Sublette K. Effectiveness of portable indoor air
1130 cleaners: sensory testing results. *Indoor Air* 1994;4:179–88.
- 1131 Shaughnessy R, Sextro R. What is an effective portable air cleaning device? A review. *J.*
1132 *Occup. Environ. Hyg.* 2006;3:169–81.
- 1133 Singh R, Debarati PD, Jain RK. Biofilms: implications in bioremediation. *Trends*
1134 *Microbiol.* 2006;14:389–97.
- 1135 Staudinger J, Roberts PV. A critical review of Henry's law constants for environmental
1136 applications. *Crit. Rev. Environ. Sci. Technol.* 1996;26:205–97.
- 1137 Subba-Rao RV, Rubin HE, Alexander M. Kinetics and extent of mineralization of organic
1138 chemicals at trace levels in freshwater and sewage. *Appl. Environ. Microb.*
1139 *1982;43:1139–50.*
- 1140 Sundell J. On the history of indoor air quality and health. *Indoor Air* 2004;14:51–8.
- 1141 Torres EM, Basrai SS, Kogan V. Evaluation of two biotechnologies controlling POTW air
1142 emissions. Proceedings of 1996 USG-TRG Conference on Biofiltration. Los Angeles,
1143 CA: University of Southern California; 1996. p. 182–97.
- 1144 Tros ME, Bosma TNP, Schraa G, Zehnder AJB. Measurement of minimum substrate
1145 concentration (S_{min}) in a recycling fermentor and its prediction from the kinetic
1146 parameters of *Pseudomonas sp.* Strain B13 from batch and chemostat cultures. *Appl.*
1147 *Environ. Microb.* 1996;62:3655–61.
- 1148 US EPA. Air and steam stripping of toxic pollutants. Tech. Rep. EPA-68-03-002.
1149 Cincinnati, OH, USA: Industrial Environmental Research Laboratory; 1982.
- Q8 1150 US EPA. Indoor Air Quality. <http://www.epa.gov/iaq/index.htm>.
- 1151 van der Kooij D, Vrouwenvelder HS, Veenendaal HR. Kinetic aspects of biofilm
1152 formation on surfaces exposed to drinking water. *Water Sci. Technol.* 1995;32:61–5.
- Q9 1153 US Green Building Council. www.usgbc.org.
- 1154 Van Groenestijn JW, Hesselink PGM. Biotechniques for air pollution control.
1155 *Biodegradation* 1993;4:283–301.
- 1156 Van Groenestijn JW, Kraakman NJR. Recent developments in biological waste gas
1157 purification in Europe. *Chem. Eng. J.* 2005;113:85–91.
- 1158 Vaughan TL, Strader C, Davis S, Daling JR. Formaldehyde and cancers of the pharynx,
1159 sinus, and nasal cavity: II. Residential exposures. *Int. J. Cancer* 1986;38:685–8.
- 1160 Vergara A, Haaren B, Revah S. Phase partition of gaseous hexane and surface
1161 hydrophobicity of *Fusarium solani* when grown in liquid and solid media with
1162 hexanol and hexane. *Biotechnol. Lett.* 2006;28:2011–7.
- 1163 Wallace LA. Personal exposure to 25 volatile organic compounds. EPA's 1987 team study
1164 in Los Angeles. California. *Toxicol. Ind. Health* 1991;7:203–8.
- 1165 Wallace LA. Human exposure to volatile organic pollutants: implications for indoor air
1166 studies. *Annu. Rev. Energy Environ.* 2001;26:269–301.
- 1167 Wargocki P, Wyon DP, Baik YK, Clausen G, Fanger PO. Perceived air quality, sick building
1168 syndrome (SBS) symptoms and productivity in an office with two different
1169 pollution loads. *Indoor Air* 1999;9:165–79.
- 1170 Wargocki P, Sundell J, Bischof W, Brundrett G, Fanger PO, et al. Ventilation and health in
1171 non-industrial indoor environments: report from a European Multidisciplinary
1172 Scientific Consensus Meeting (EUROVEN). *Indoor Air* 2002;12:113–28.
- 1173 Weisel C, Zhang J, Turpin BJ, Morandi MT, Colome S, et al. Relationships of indoor,
1174 outdoor, and personal air (RIOPA), Part I. Collection Methods and descriptive
1175 Analyses. Health Effect Institute; 2005. p. 1–144.
- 1176 WHO. Air quality guidelines for Europe. Second Edition. Copenhagen: World Health
1177 Organisation; 2000.
- 1178 Wieslander G, Norbäck D, Björnsson E, Janson C, Boman G. Asthma and the indoor
1179 environment: the significance of emission of formaldehyde and volatile organic
1180 compounds from newly painted indoor surfaces. *Int. Arch. Occup. Environ. Health*
1181 *1997;69:115–24.*
- 1182 Wolkoff P, Clausen PA, Nielsen PA, Molhave L. The Danish Twin Apartment Study, Part I:
1183 Formaldehyde a long term VOC measurements. *Indoor Air* 1991;1:478–90.
- 1184 Wolkoff P, Clausen PA, Jensen B, Nielsen GD, Wilkins CK. Are we measuring the relevant
1185 indoor pollutants? *Indoor Air* 1997;7:92–106.
- 1186 Wolkoff P, Nielsen GD. Organic compounds in indoor air their relevance for perceived
1187 indoor air quality? *Atmos. Environ.* 2001;35:4407–17.
- 1188 Wolkoff P. Trends in Europe to reduce the indoor air pollution of VOCs. *Indoor Air*
1189 *2003;13:5–12.*
- 1190 Wolverton BC, McDonald RC, Watkins Jr EA. Foliage plants for removing indoor air
1191 pollutants from energy-efficient homes. *Econ. Bot.* 1984;38:224–8.
- 1192 Wolverton, B.C., Johnson, A., Bounds, K., Interior landscape plants for indoor air
1193 pollution abatement, National Aeronautics and Space Administration, 1989. p.1–22.
- 1194 Wood RA, Burchett MA, Alquezar R, Orwell RL, Tarran J, Torpy F. The potted-plant
1195 microcosm substantially reduces indoor air VOC pollution: 1. Office field-study.
1196 *Water Air Soil Pollut.* 2006;175:163–80.
- 1197 Yu H, Kim BJ, Rittmann BE. A two-step model for the kinetics of BTX degradation and
1198 intermediate formation by *Pseudomonas putida* F1. *Biodegradation* 2001;12:465–75.
- 1199 Yu C, Crump D. A review of the emission of VOCs from polymeric materials used in
1200 buildings. *Build. Environ.* 1998;33:357–74.
- 1201 Zhang JJ, Smith KR. Indoor air pollution: a global problem. *Br. Med. Bull.*
1202 *2003;68:209–25.*
- 1203 Zhou X, Mopper K. Apparent partition coefficients of 15 carbonyl compounds between
1204 air and seawater and between air and freshwater: implications for air-exchange.
1205 *Environ. Sci. Technol.* 1990;24:1864–9.
- 1206 Zilli M, Camogli G, Nicoletta C. Detachment and emission of airborne bacteria in gas-
1207 phase biofilm reactors. *Biotechnol. Bioeng.* 2005;91:707–14.
- 1208 Zumairi MS, Roulet CA, Tham KW, Sekhar SC, Cheong KWD, Wong NH, et al. A
1209 comparative study of VOCs in Singapore and European office building. *Build.*
1210 *Environ.* 2006;41:316–29.
- 1211

1212