



HAL
open science

Using Cold Plasmas to Improve Electrochemical Sensors and vice versa

Camille Colin, Vasilica Badets, Fanny Girard-Sahun, Pauline Lefrançois, U Botsos-Margerit, Dodzi Zigah, Sylvie Blanc, Neso Sojic, Franck Clement, Stéphane Arbault

► To cite this version:

Camille Colin, Vasilica Badets, Fanny Girard-Sahun, Pauline Lefrançois, U Botsos-Margerit, et al.. Using Cold Plasmas to Improve Electrochemical Sensors and vice versa. 9th International Workshop on Surface Modification for Chemical and Biochemical Sensing, Nov 2019, Żelechów,, Poland. <hal-03027635>

HAL Id: hal-03027635

<https://univ-pau.hal.science/hal-03027635v1>

Submitted on 27 Nov 2020

HAL is a multi-disciplinary open access archive for the deposit and dissemination of scientific research documents, whether they are published or not. The documents may come from teaching and research institutions in France or abroad, or from public or private research centers.

L'archive ouverte pluridisciplinaire **HAL**, est destinée au dépôt et à la diffusion de documents scientifiques de niveau recherche, publiés ou non, émanant des établissements d'enseignement et de recherche français ou étrangers, des laboratoires publics ou privés.



HAL Authorization



Using Cold Plasmas to Improve Electrochemical Sensors and *vice versa*

Colin Camille,¹ Badets Vasilica,¹ Girard Fanny,^{1,2} Lefrançois Pauline,¹
Botsos-Margerit Ugo,¹ Zigah Dodzi,¹ Blanc Sylvie,²
Sojic Neso,¹ Clément Franck,² Arbault Stéphane¹

1. *University of Bordeaux, Institute of Molecular Sciences, NSysA lab.
CNRS UMR 5255, ENSCBP, Pessac, France*

2. *UPPA, IPREM, CNRS UMR 5254, 2 avenue Président Angot, 64000 Pau, France.*



What is a plasma ?

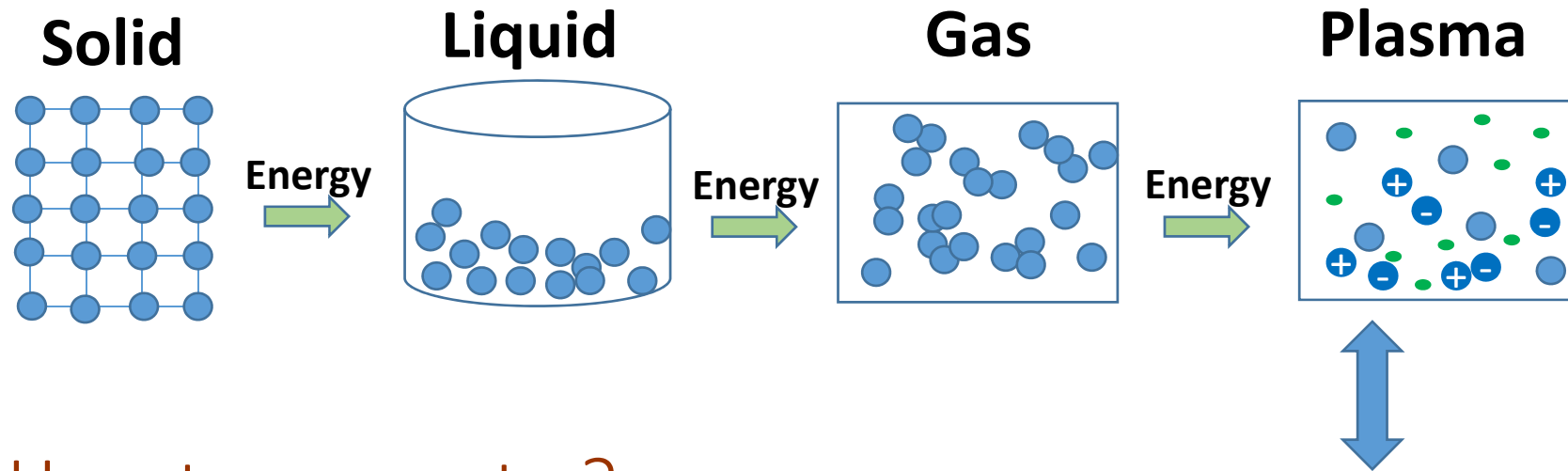

How to generate ?

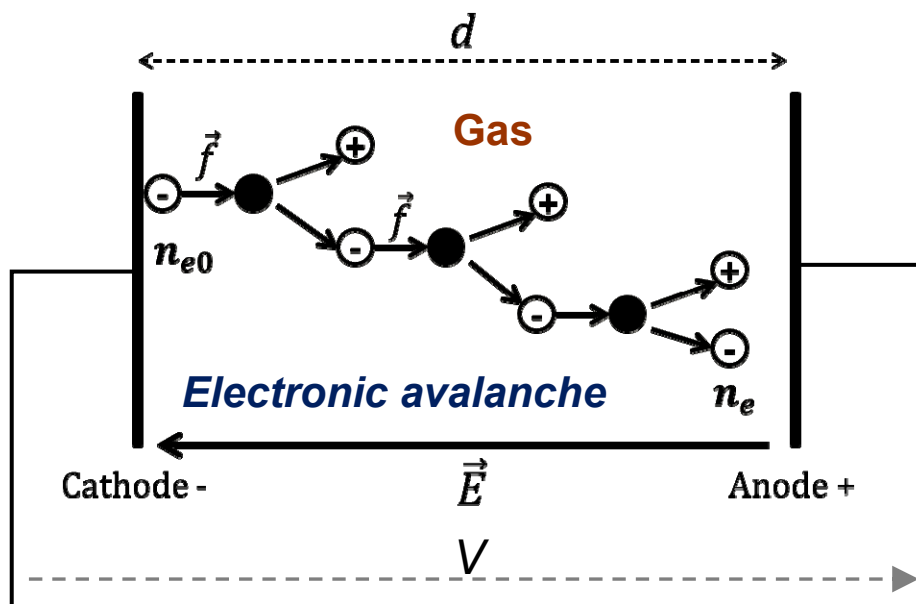

- Electrons
- Ions @ fundamental / excited states
 - Neutral atoms and molecules @ fundamental / excited states
 - Photons

Types of plasma :

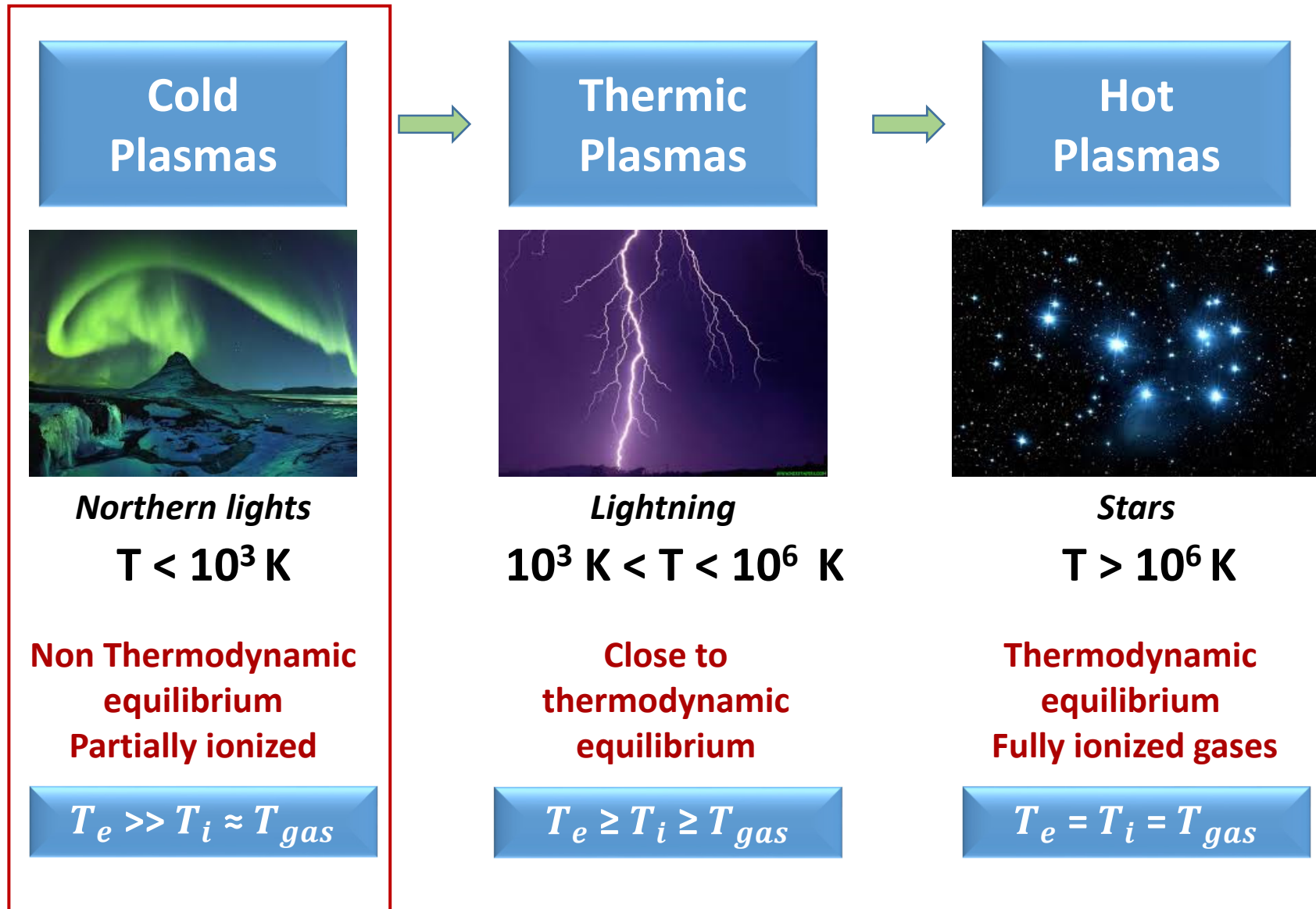

Ionization degree : $\alpha < 10^{-4}$

Easiest way to work with plasmas ?

Glow discharge plasmas : Room T°- gases at Low pressure (vacuum) – RF field



Typical uses :

1. removal of hydrocarbons - Micro-cleaning - degreasing in oxygen plasma
2. Mechanical cleaning :
Due to the kinetic energy of impacting ions, atoms and molecules forming coatings can be gradually removed.
3. Structuring - physical etching
4. **Formation-Reduction of oxide layers – surface chemical activation**

Advantages :

- **Plasma cleaning has unique advantages :**
- Cleaning even in the finest cracks and gaps
- Cleaning of all component surfaces in a single step
- Residue-free removal of degradation products by vacuum suction
- No damage to solvent-sensitive surfaces by chemical cleaning agents
- Also removes fine molecular residues
- Immediate further processing is possible (and beneficial). No venting and removal of solvents required
- Low process costs
- **Modulation of hydrophilicity/hydrophobicity**



Detection in biochemical buffers of Hydrogen Peroxide With Platinized Microelectrodes

➤ Operating conditions :

- selective detection of H_2O_2 between $\approx 10 \text{ nM}$ to $100 \mu\text{M}$
- analyses in specific buffers (Manitol, Phosphates, EGTA...)
- response time $\leq 1 \text{ sec}$; steady-state monitoring

⇒ Microelectrode with a nano-structured Platinum surface : high Surface/Area

Electrodeposition of « Black Platinum »

$E = -60 \text{ mV vs. Ag/AgCl}$

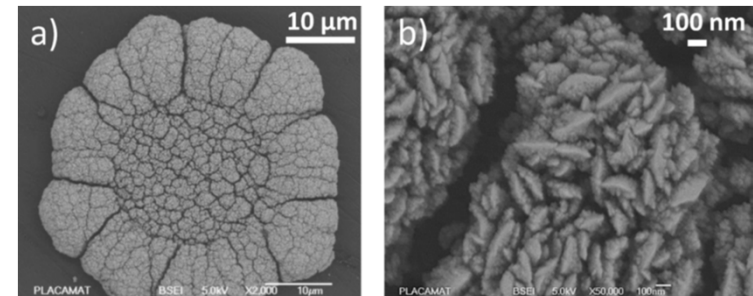
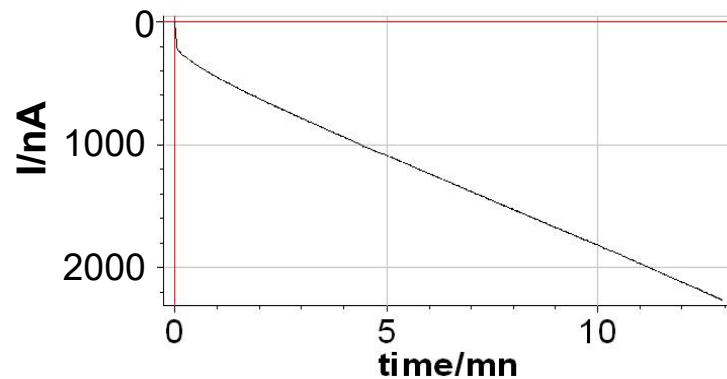
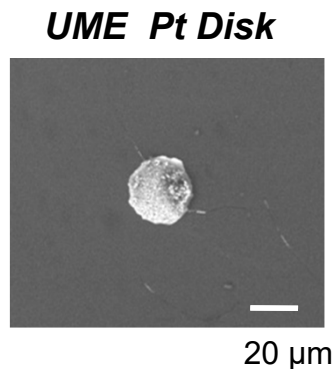

⇒ active surface x 10-500

Sensitivity / H_2O_2 as f($[\text{H}_2\text{PtCl}_6]$, $[\text{Pb}(\text{CH}_3\text{CO}_2)_2]$, coulometric charge)

Effect of an Oxygen Plasma on Platinized Microelectrode Responses

➤ **Oxygen plasma treatment:** 30 W; 300 mTorr 100 % O₂; 20 min. (Harrick Plasma)

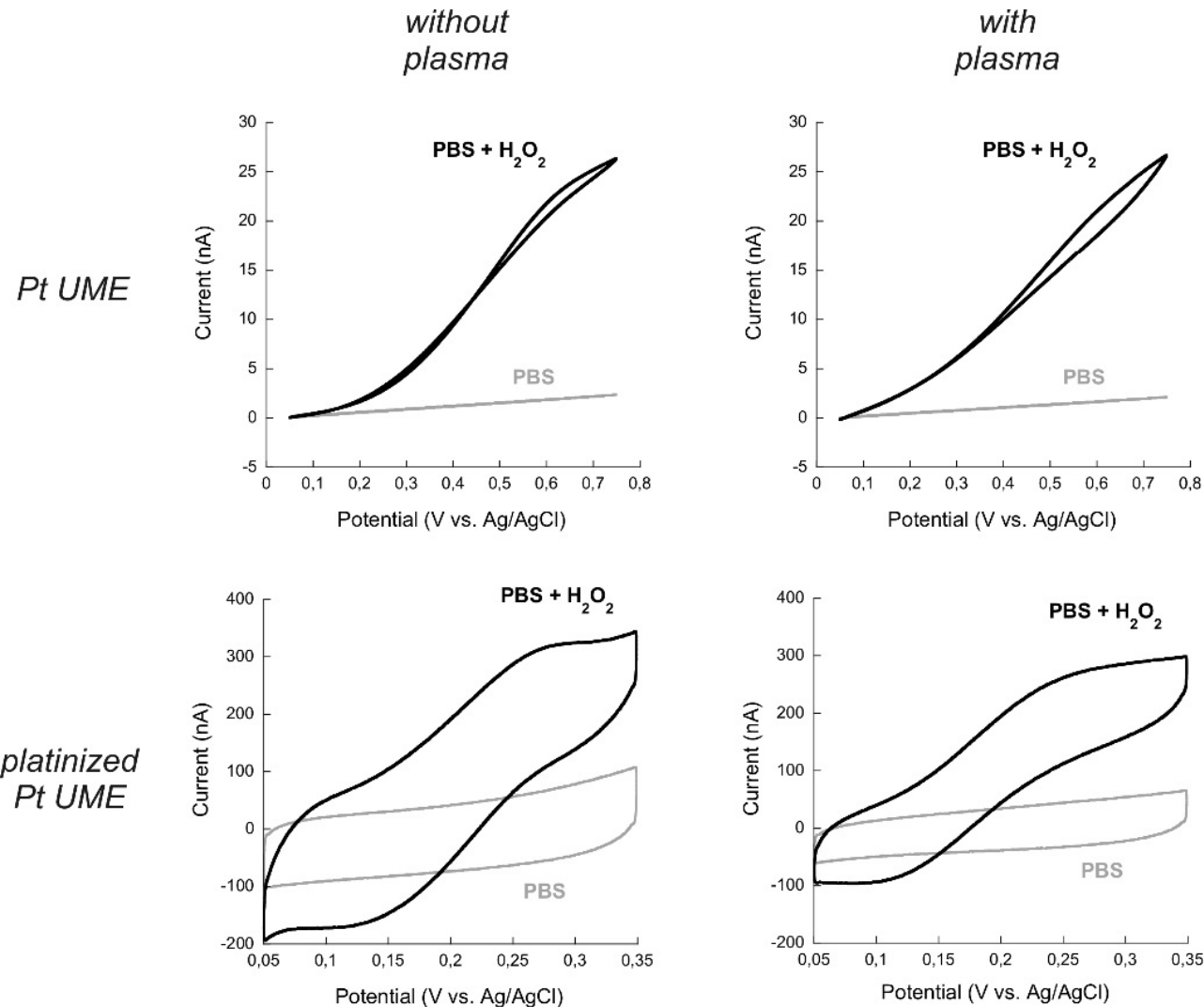

⇒ I_{faradaic} / I_{capacitive} ↗ 3-fold

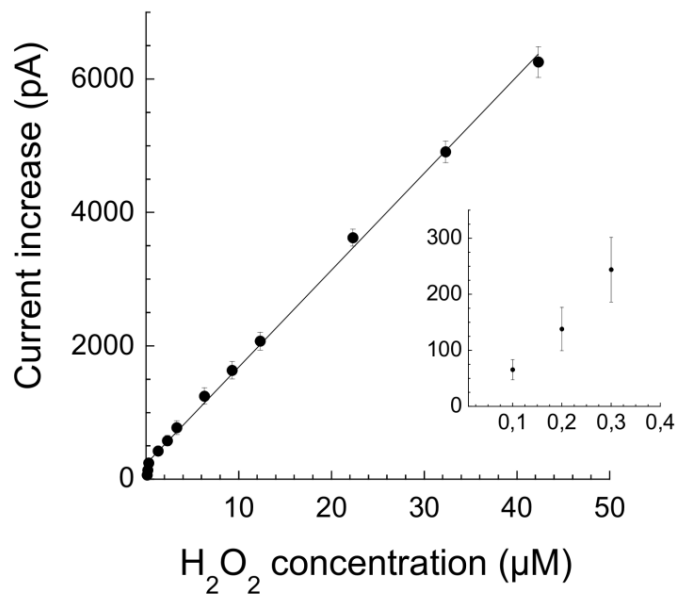
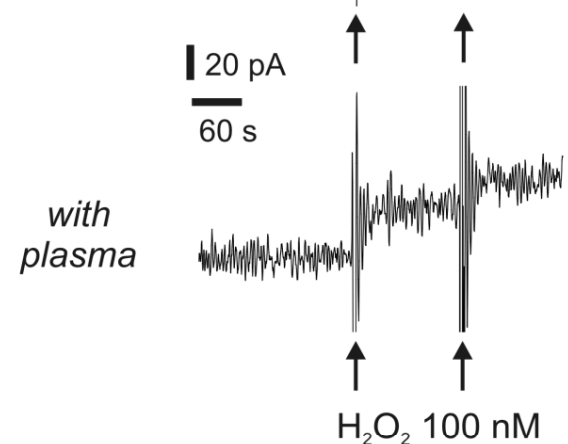
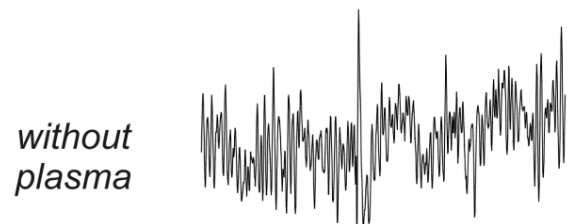

Amperometric noise

⇒ better sensitivity (LOD = 100 → 30 nM)

XPS – Pt4f analyses

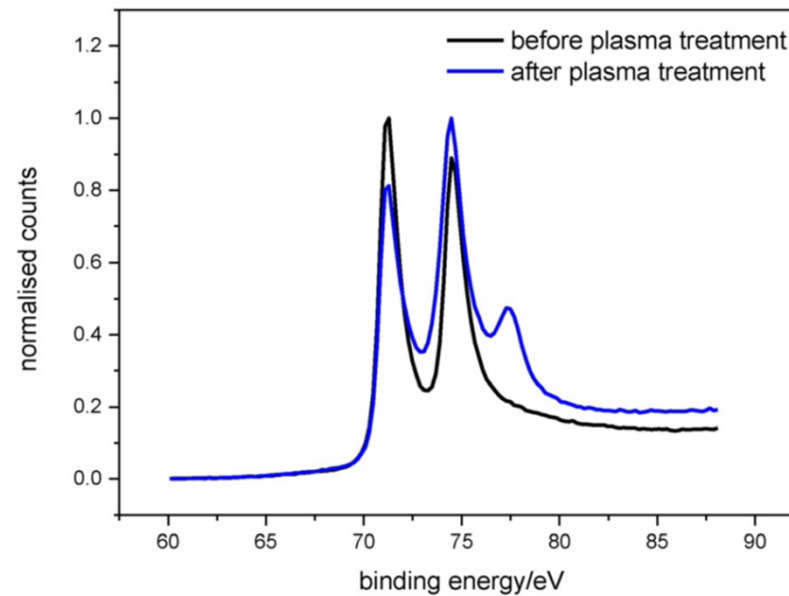

PtO₂ oxides increase / Pt⁰ and PtO

Outer-layer surface modification (few nm)

Development of Electrochemical Microchips for Bioenergetic Sensing

Multiple Electrochemical cells - ultramicroelectrode arrays on a silicon chip :

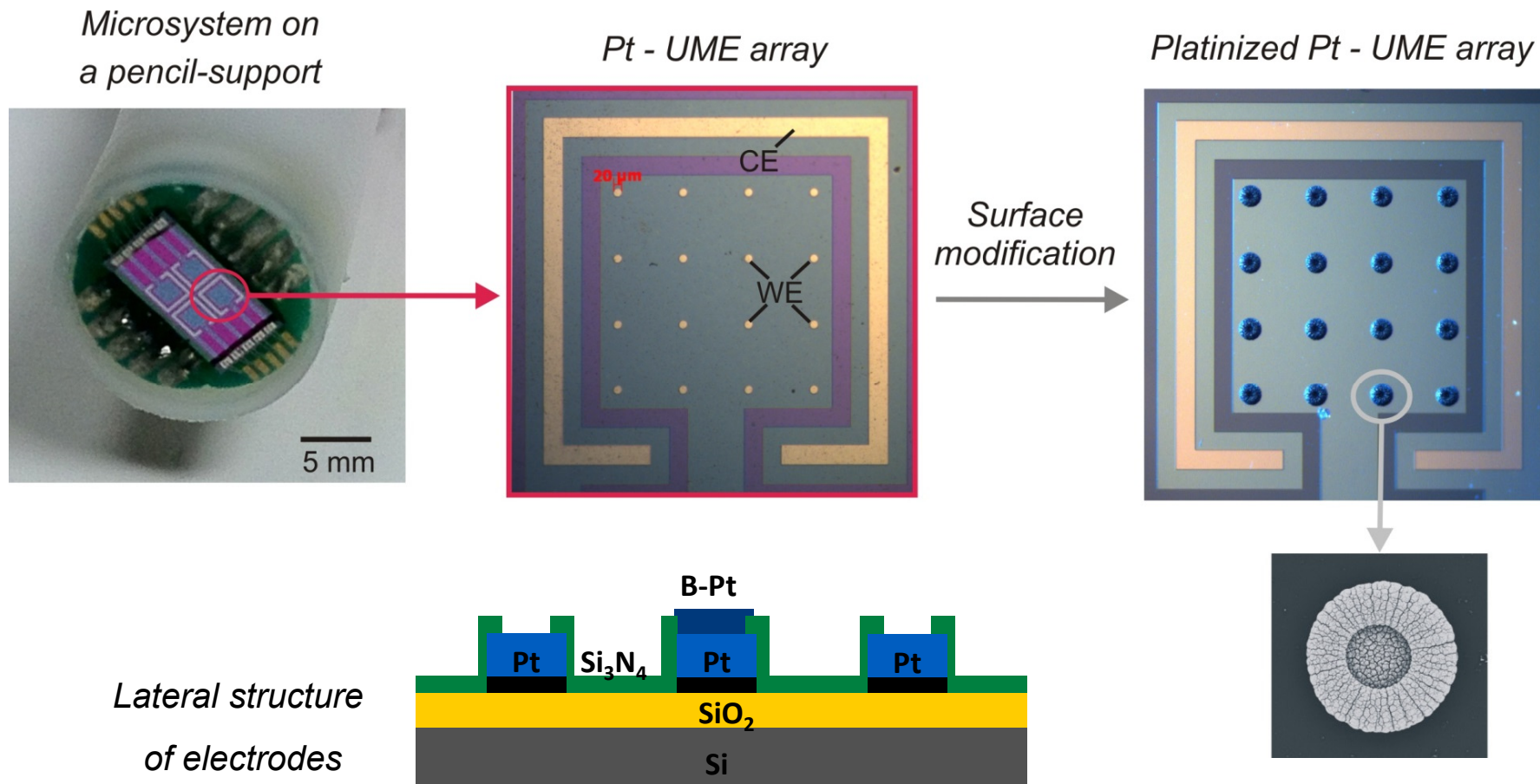

Chrono-amperometric responses to H_2O_2 as function of the platinization charge :

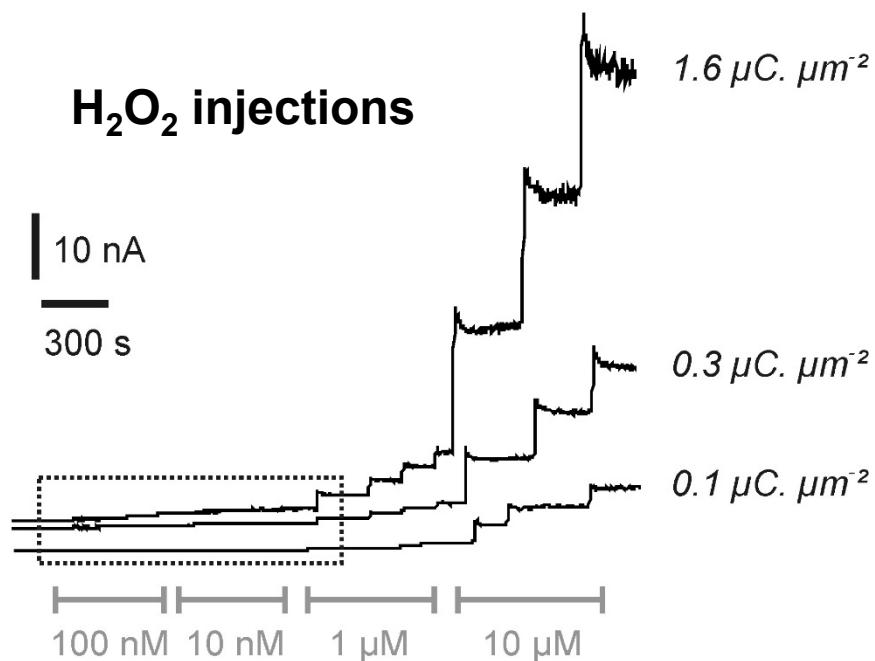

Test in an oxygraphy chamber

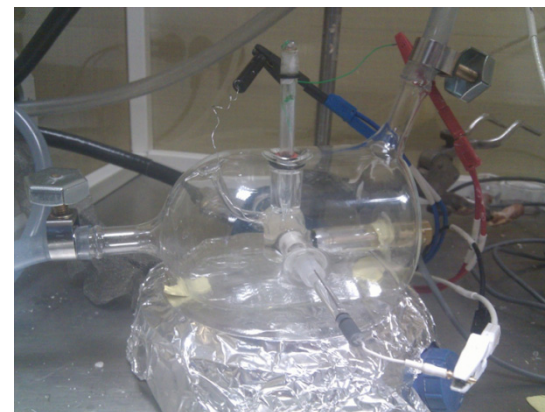

Mitochondrial phosphate buffer, $T=28^\circ\text{C}$, 900 rpm

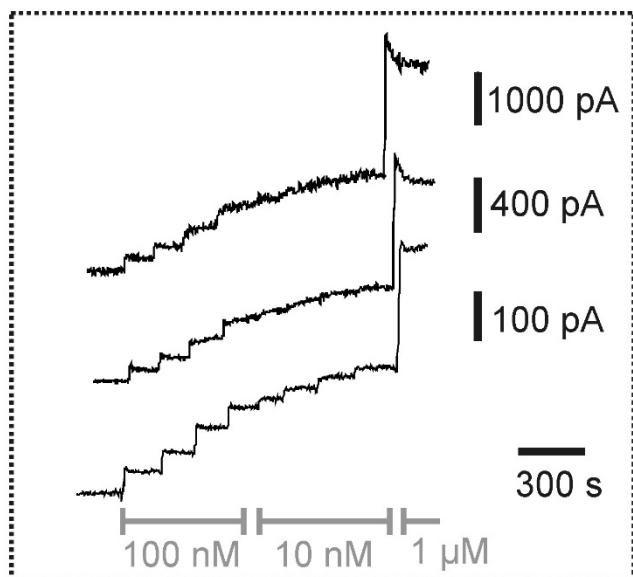

Sensitivity for H_2O_2 : 10 nM

Linearity of response : 30 nM – 100 μM

Response-time ≤ 1 sec.

Ben-Amor S et al. *Electrochimica Acta*, **2014**, 126, 171-178

Coupled Detection of O_2 and H_2O_2 on Yeast Mitochondria

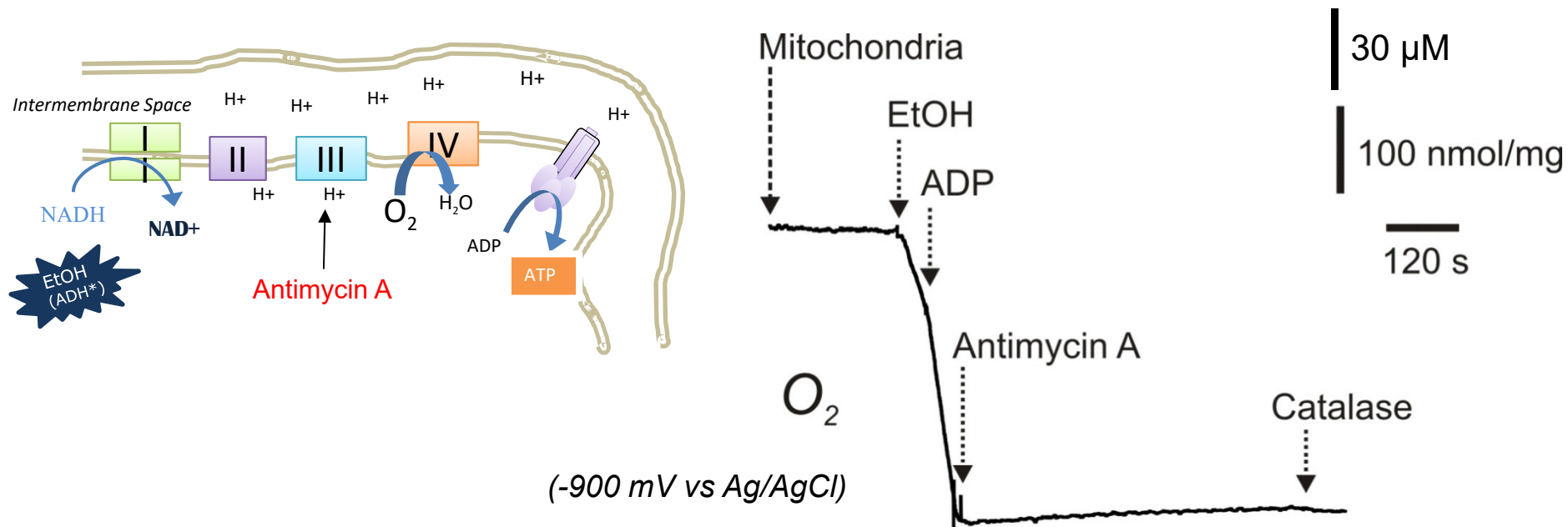

Microelectrode array-based sensor

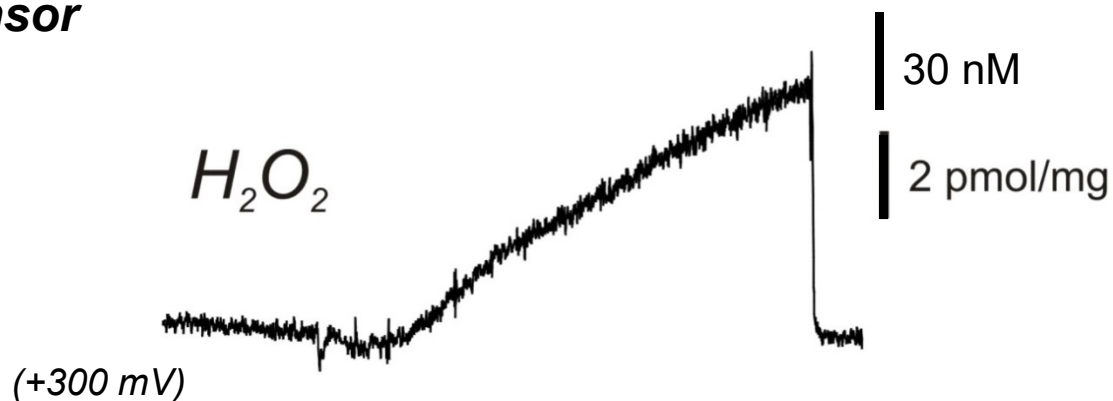
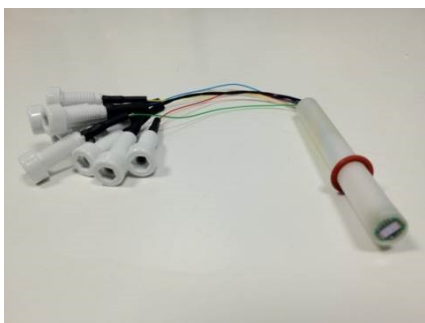

Direct quantification of H_2O_2 release / O_2 consumption

Effects of Oxygen Plasma on the Responses of Glassy Carbon Electrodes

➤ **Oxygen plasma treatment:** 30 W; 300 mTorr 100 % O₂; different exposure times

Ferrocyanide (1 mM, KCl electrolyte)

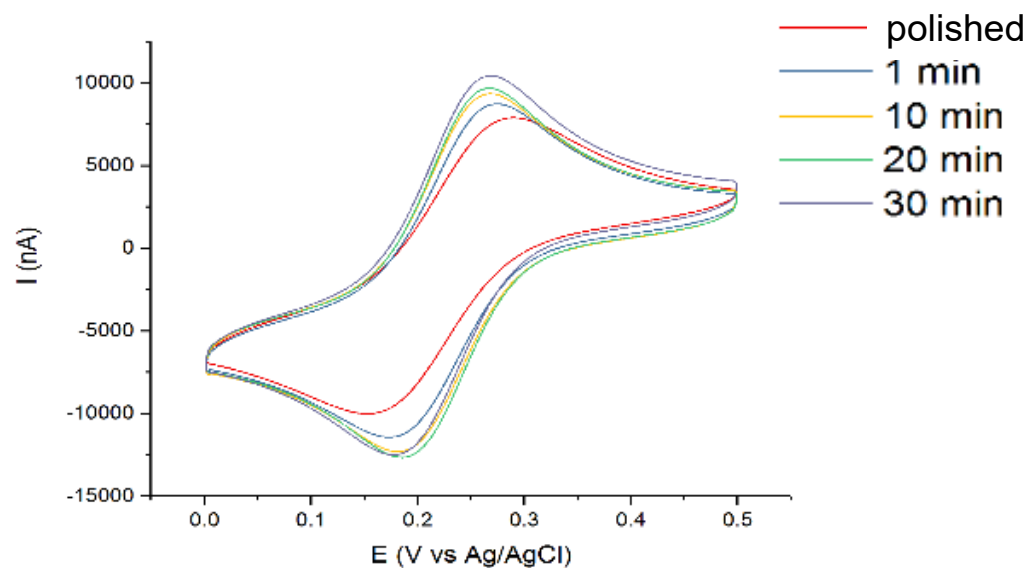

Positive effects on peak amplitudes and transfer kinetics

Ferrocenedimethanol (1 mM, KCl electrolyte)

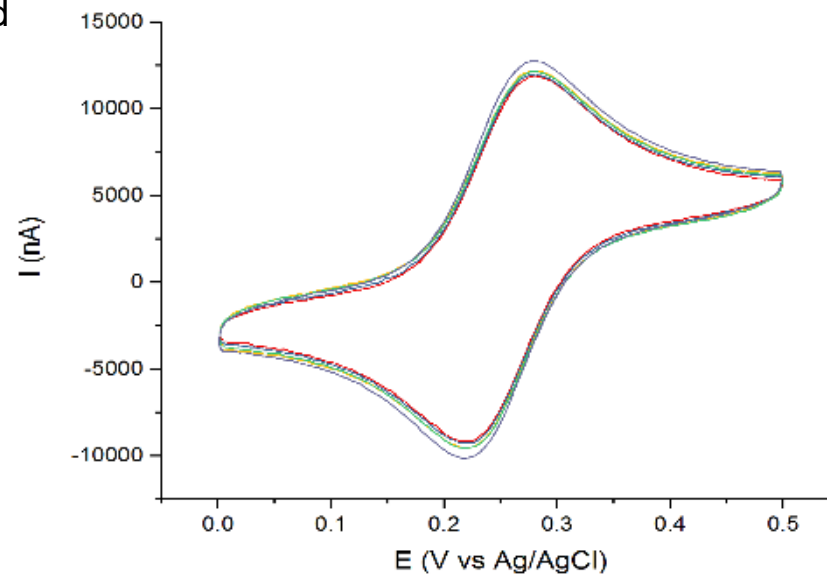

Slight effects on peaks

➤ Stability of the oxygen plasma effects if electrodes are kept in water or at air

3 electrodes in each condition ; T0, +1 day, +2 days, +4 days, +8 days

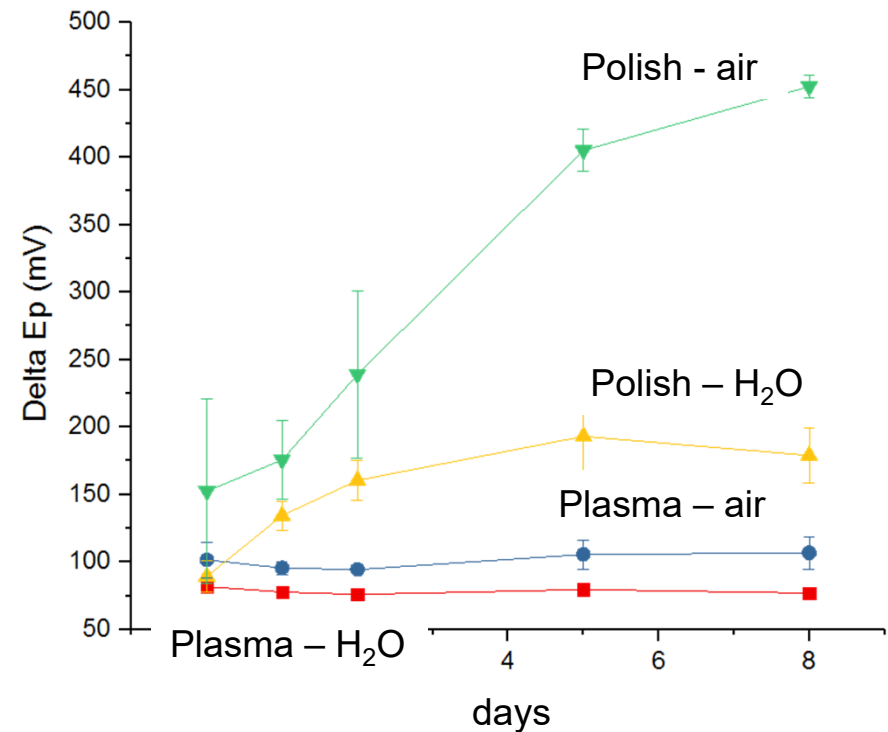
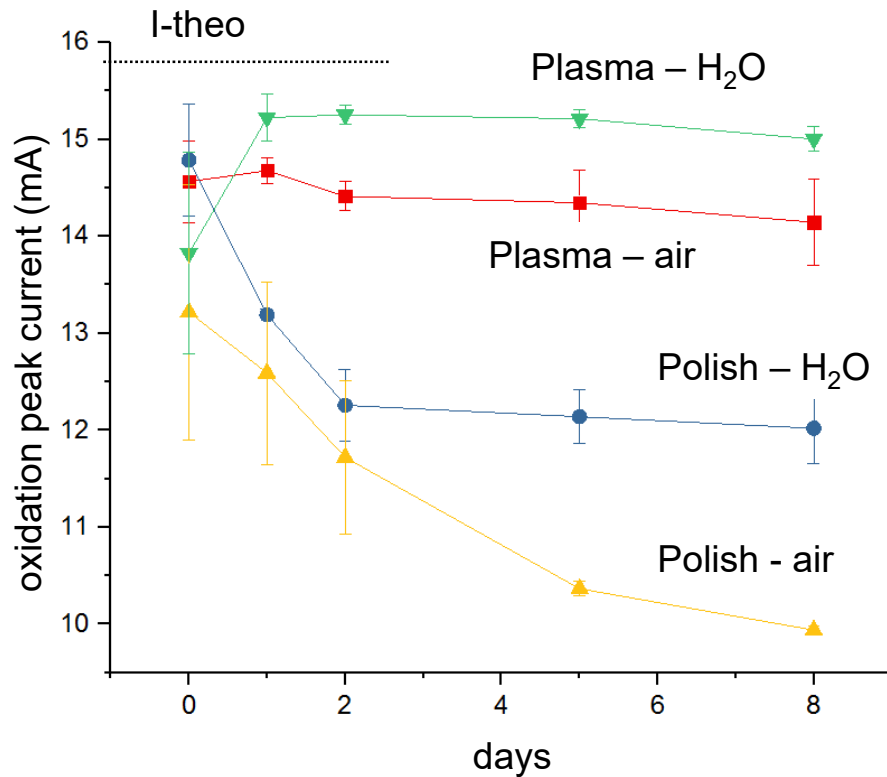

- Plasma effects are conserved over a week when electrodes are kept in water
 - XPS analyses show increase of O1s /C1s (C=O, C-O functions)
- Surface hydrophilicity increased / allows to eliminate grafted layers (ex. diazonium)

Generating Cold Atmospheric Plasmas (room temperature, ambient Pressure)

➤ **Dielectric barrier discharge setup :**

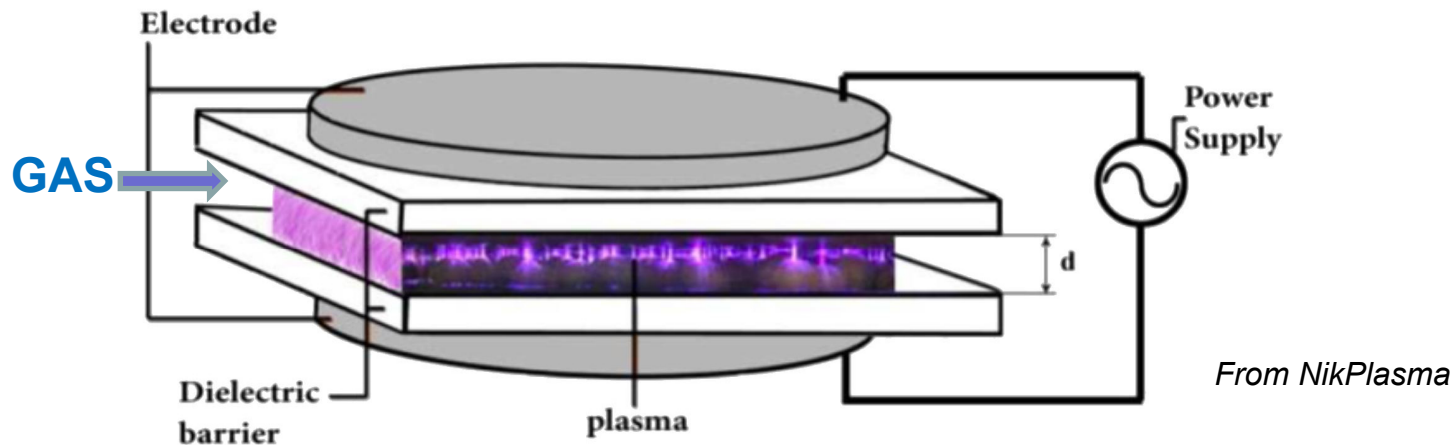

High voltage (current) AC field to ionize the gas at ambient P, T° : 10 kV/cm , kHz

Propagation of **ionization waves** in air

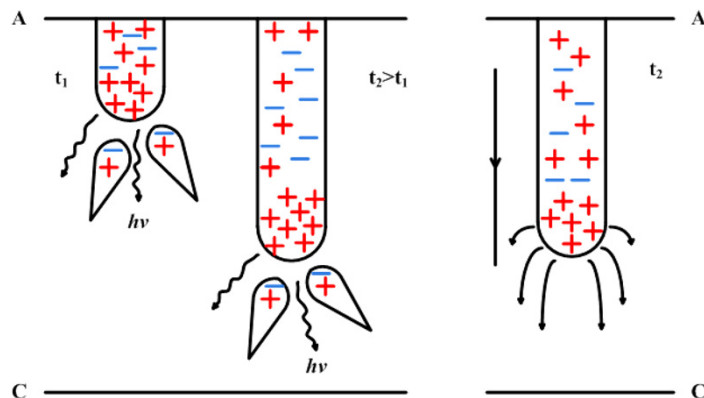

Commercial systems :

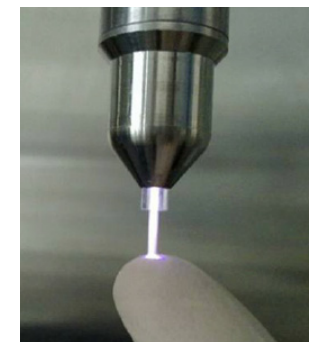

Research plasma setup:

Pr Franck Clément,

UPPA Pau, France

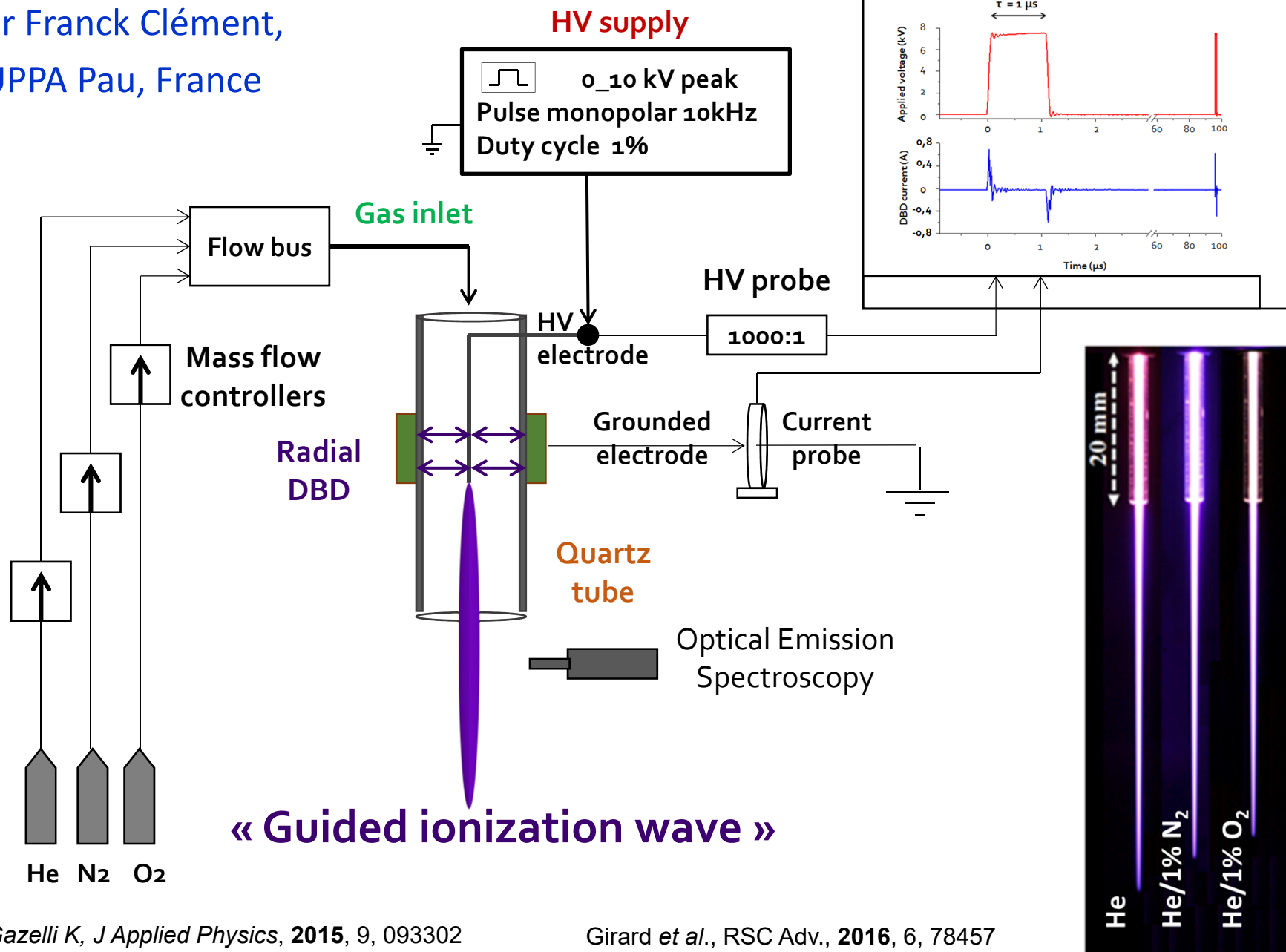

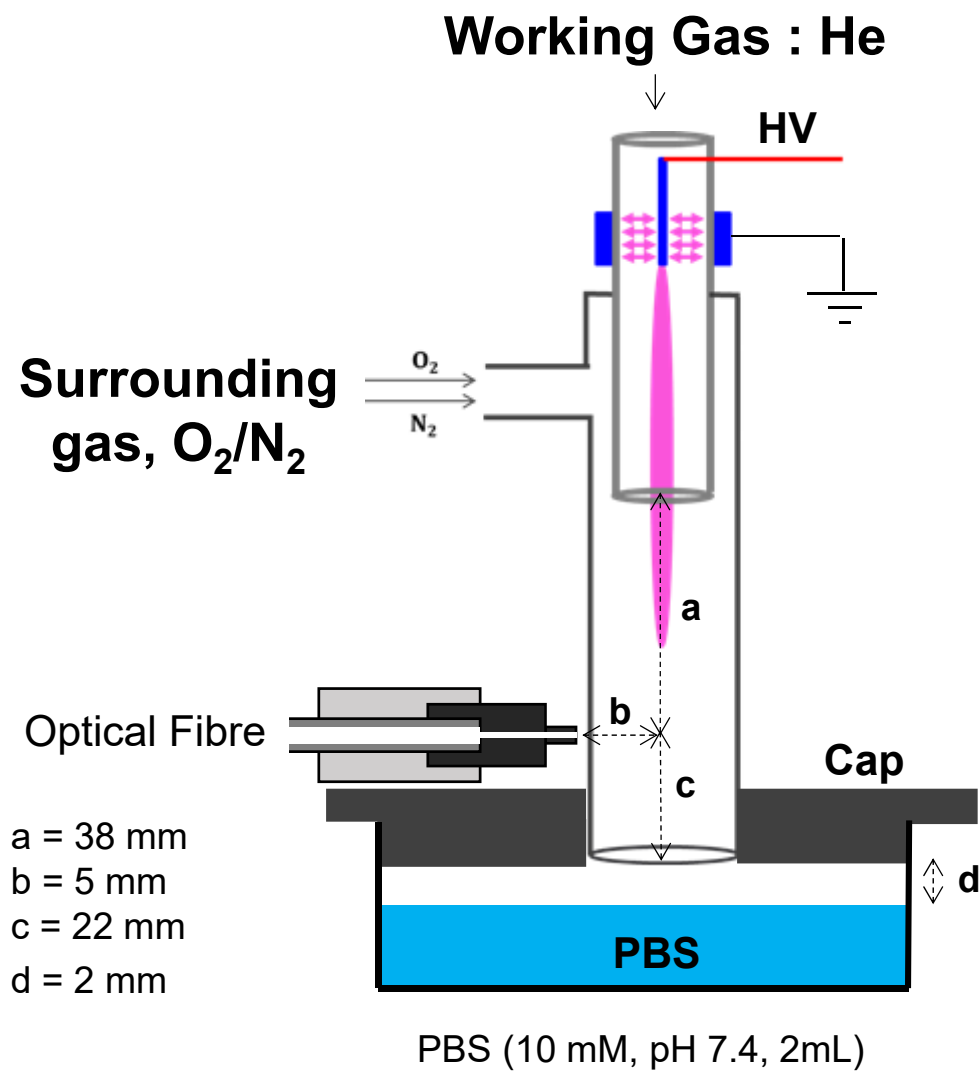

**Treatment of cells in culture or
tissue surface (skin explants)**

Diffusive Plasmas

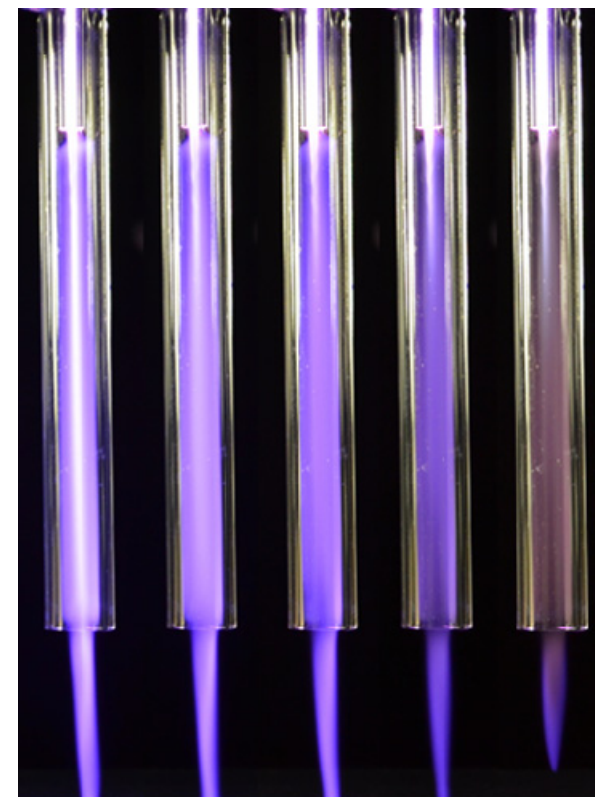

100% N₂
20% O₂/80%N₂
50% O₂/50%N₂
80% O₂/20%N₂
100% O₂

Understanding the interface between plasma and an aqueous solution

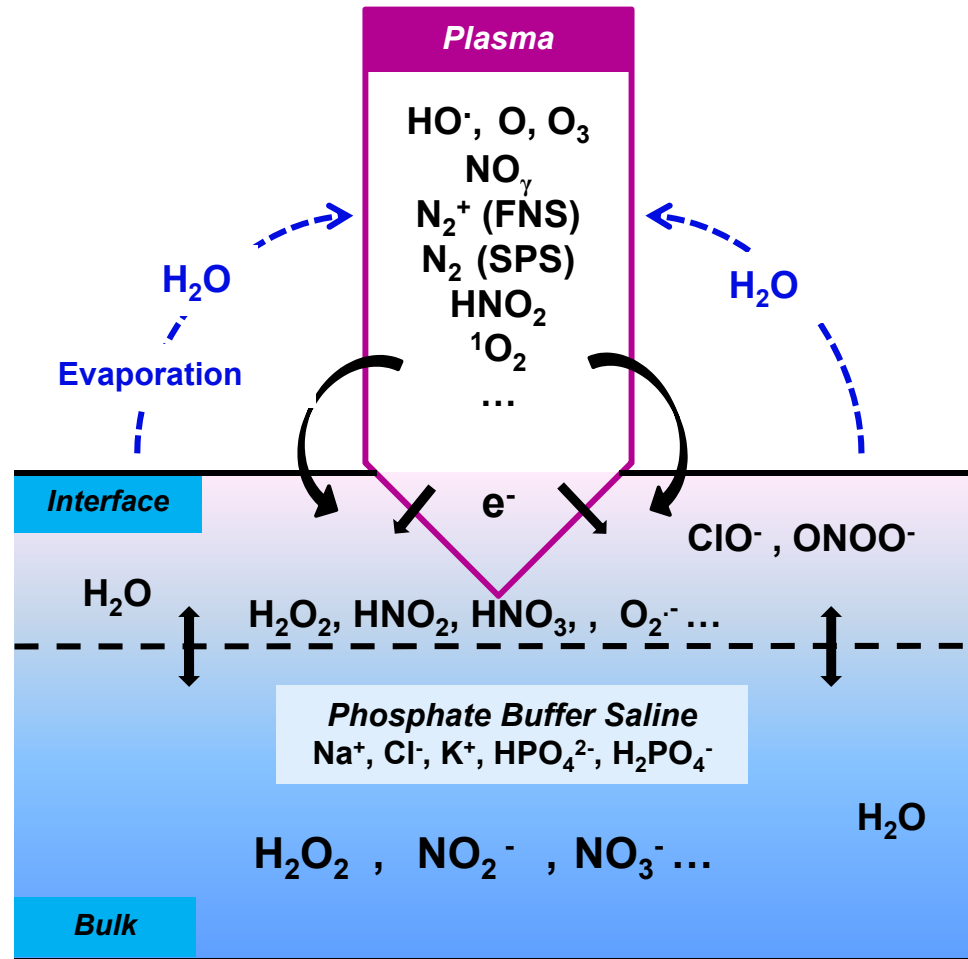

Links between chemical species in the plasma and induced chemistry in liquid ?

Girard *et al.*, RSC Adv., **2016**, 6, 78457

Dezest M *et al.*, PLoS ONE, **2017**, 12 (3), pp.e0173618

Girard F *et al.*, Phys. Chem. Chem. Phys., **2018**, 20, 9198-9210

Dezest M *et al.*, Scientific Reports, **2017**, 7, 41167

In situ monitoring of ROS-RNS generated by plasmas in aqueous solution

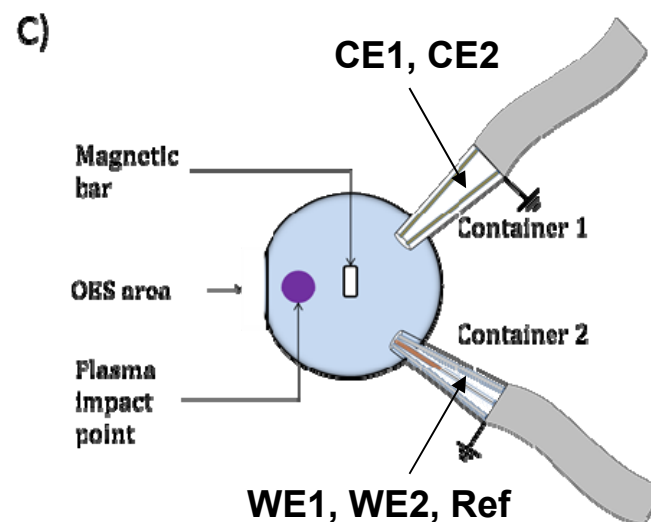
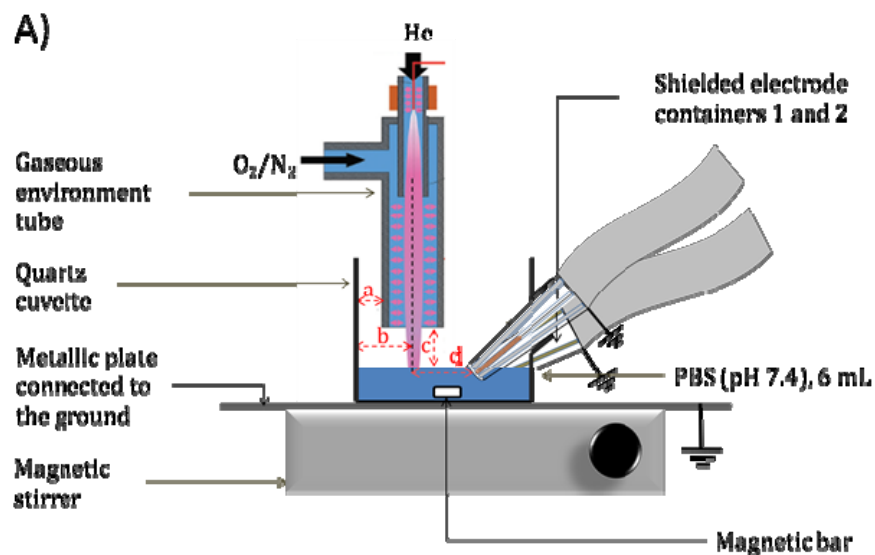

B) **Black Pt-modified microelectrode**

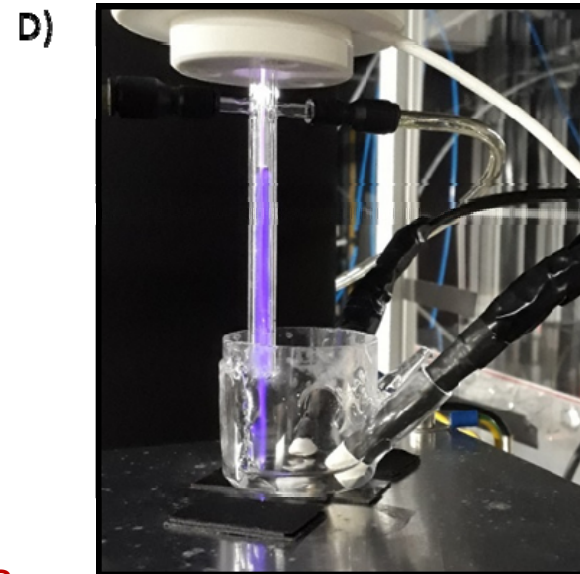
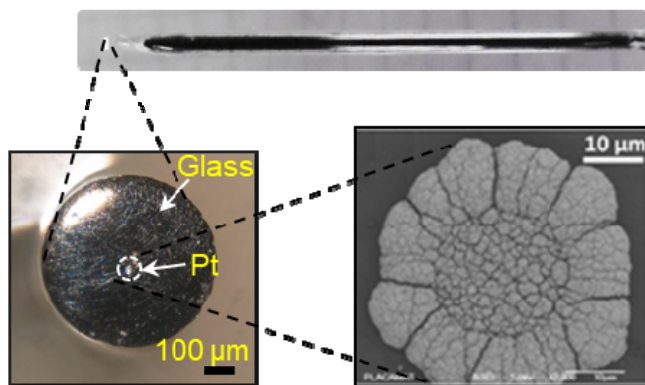

Question addressed : is sensitive electroanalysis possible next to a plasma stream ?

Pulsed local E field : 10 kV/cm, A peak currents

In situ monitoring of ROS-RNS generated by plasmas in aqueous solution

Cyclic voltammetry of $\text{Fe}(\text{CN})_6\text{K}_4$

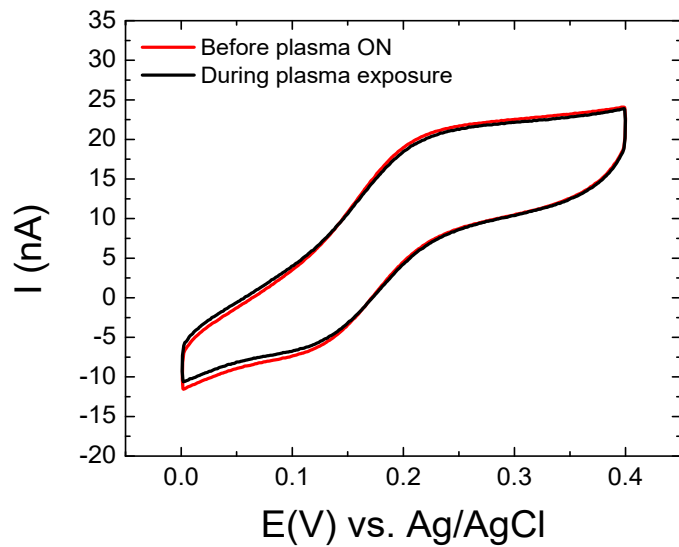

Chronoamperometry at 2 electrodes (2 distinct E)

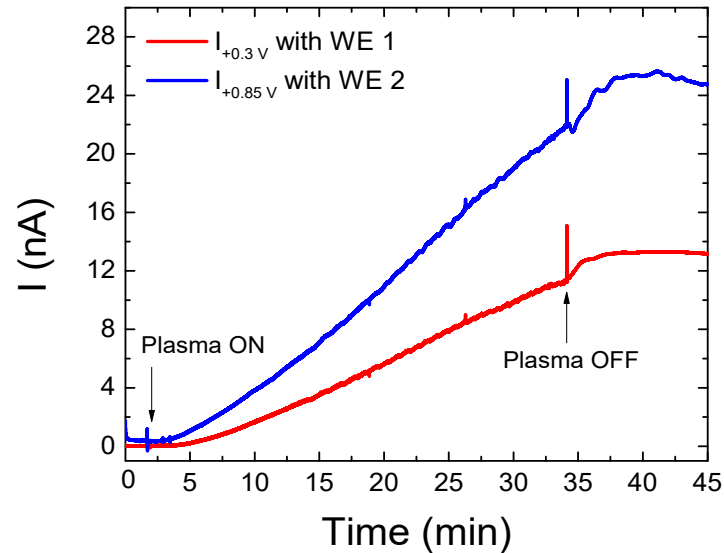

Cyclic voltammetry in PBS during plasma

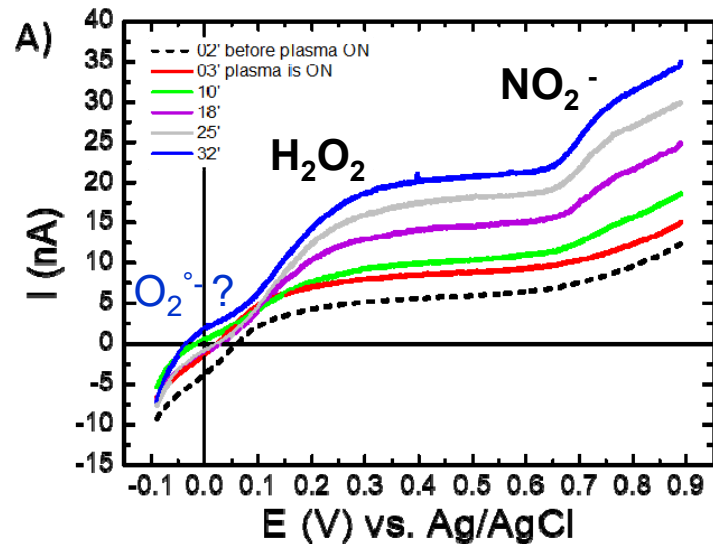

Species produced

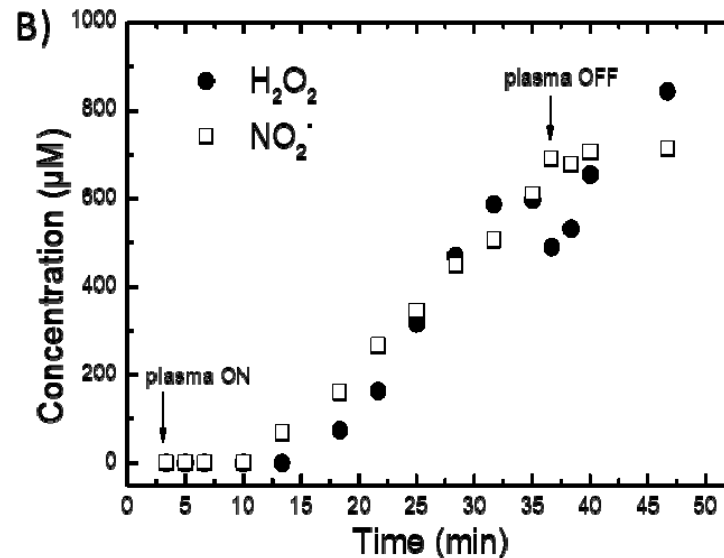

Answer to Question: YES !

Basic reactions in a plasma :

Electronic ionization

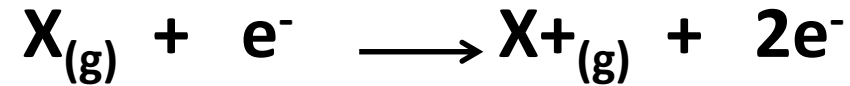

Electronic excitation

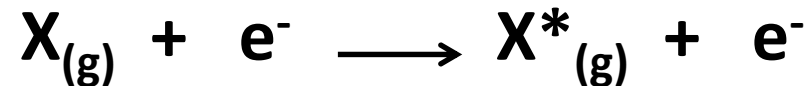

Electronic attachment

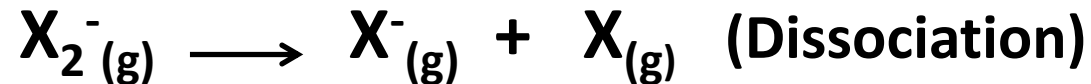
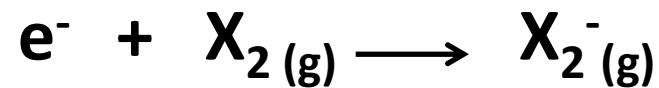

Ion-molecule collision

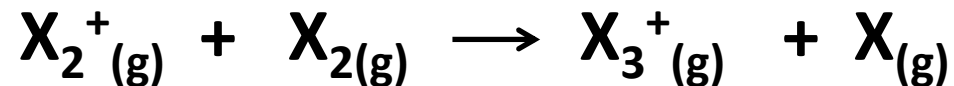

These charges generate a local electric field \vec{E}_l

Voltametric response as function of the platinization charge :

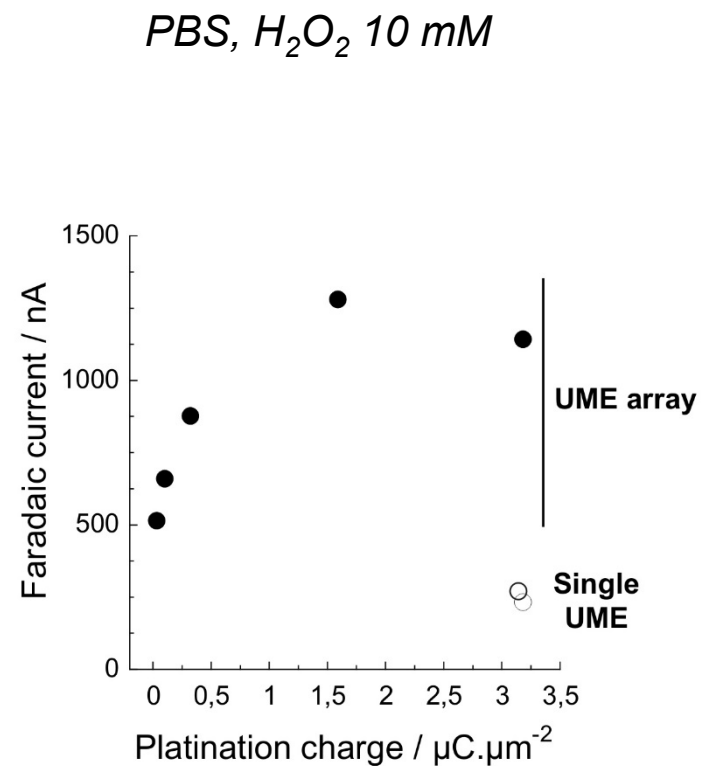
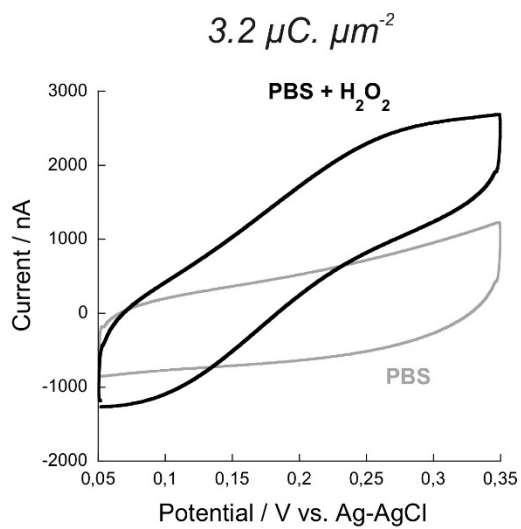
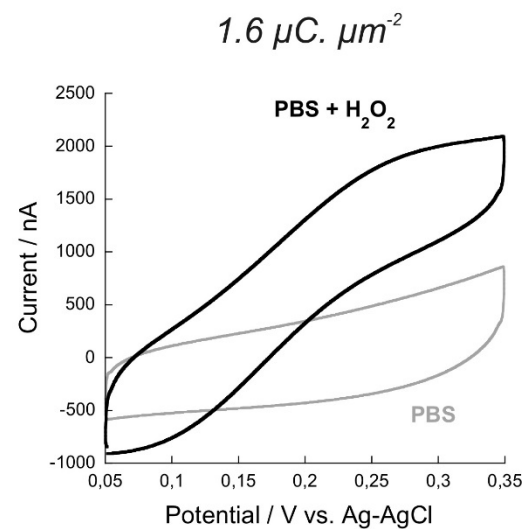
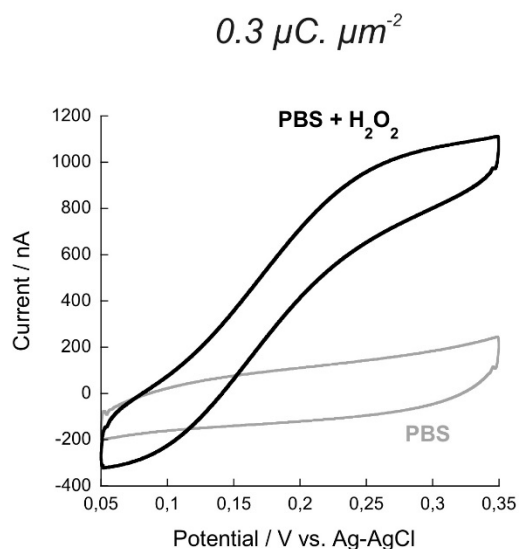
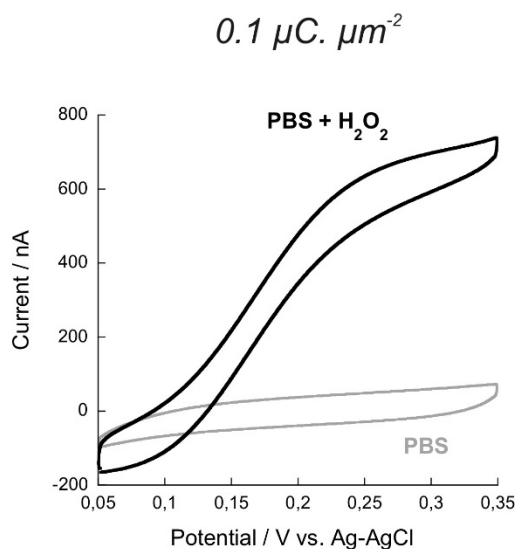

Plasma-liquid interactions

7.5 kV
10 kHz
duty cycle = 1 %

He/1%N₂



UV-visible absorption spectroscopy

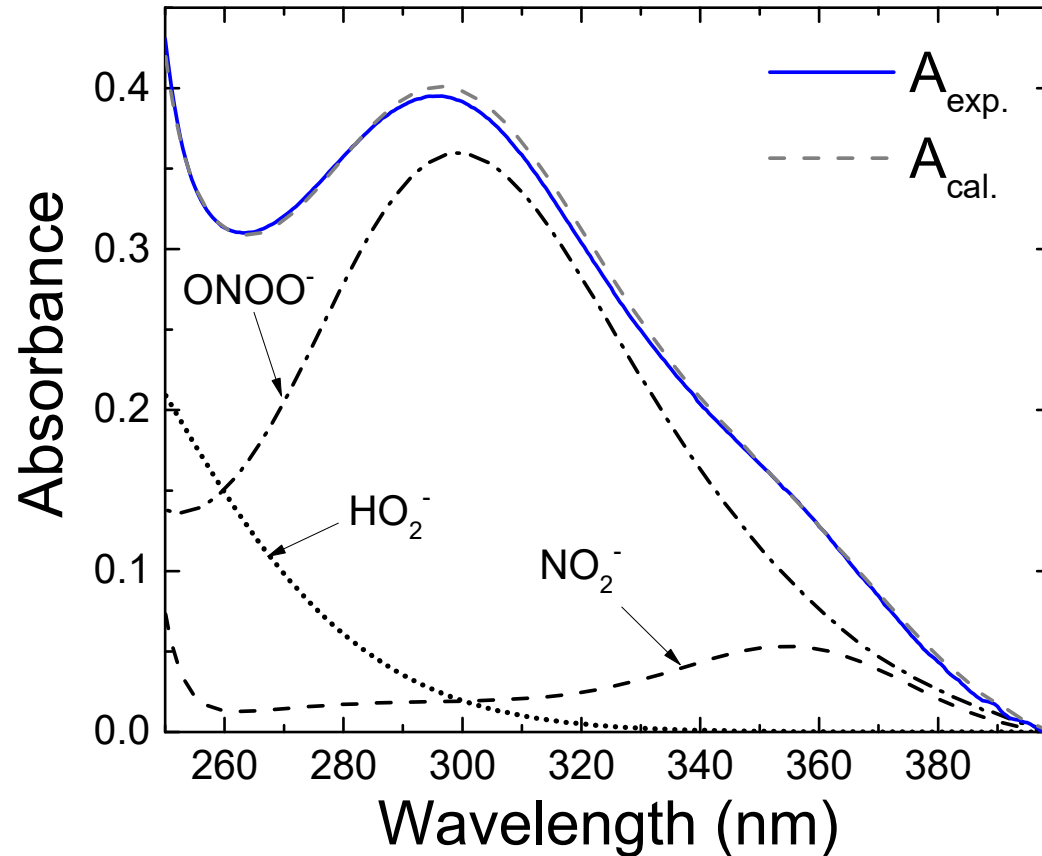

- ✓ $ONOO^-$: hypothesis validated
- ✓ $[ONOO^-] \approx 50 \mu M$ (10 minutes of treatment)
- ✓ Stabilized at pH 12 but probably also exists at pH 7.4

Plasma-liquid interactions

7.5 kV
10 kHz
duty cycle = 1 %

NO_2^- , H_2O_2 and NO_3^- quantification

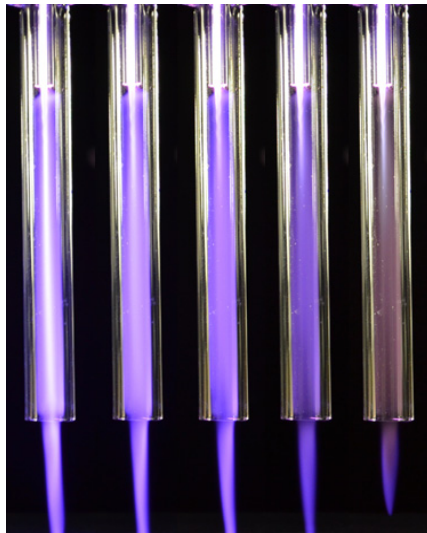

100% N_2
80% N_2 /20% O_2
50% N_2 /50% O_2
20% N_2 /80% O_2
100% O_2

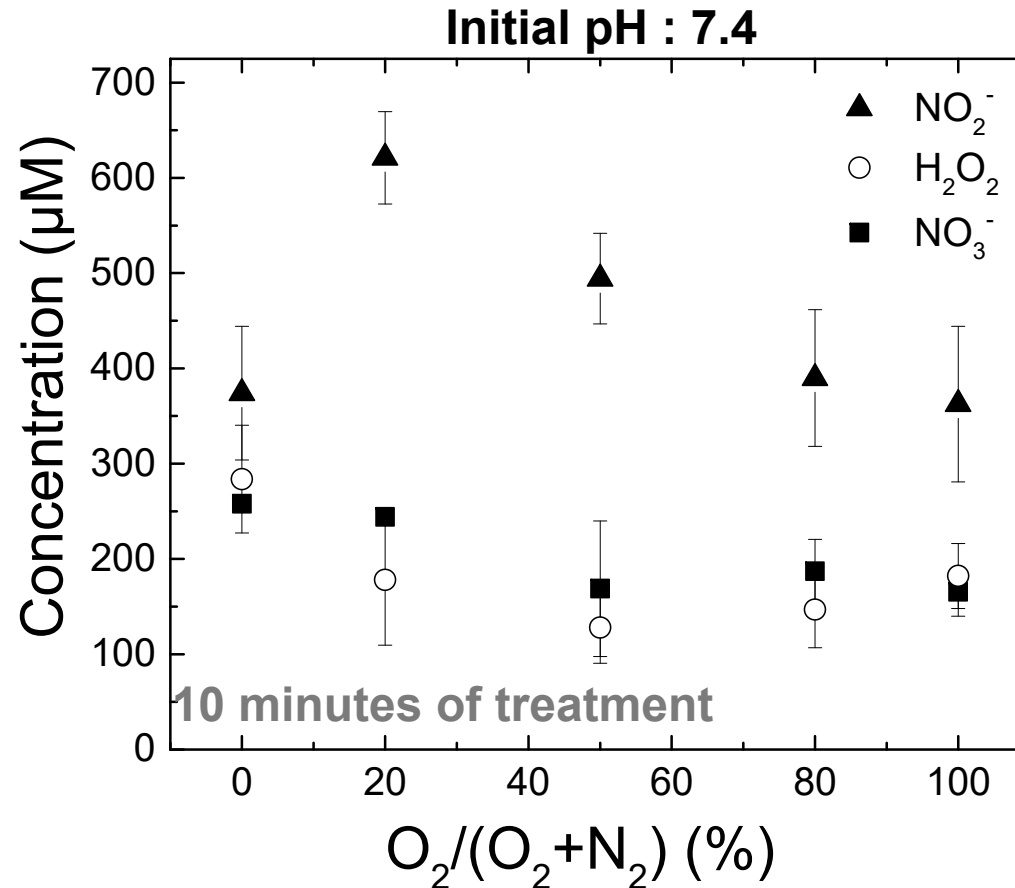

- ✓ $[\text{NO}_2^-]_{\text{max}}$ for the “air shielding” (20% O_2 /80% N_2)
- ✓ $[\text{H}_2\text{O}_2]_{\text{max}}$ and $[\text{NO}_3^-]_{\text{max}}$ for 100% N_2 in the shielding gas

Importance of the N_2 and air shielding gases, already observed by
H. Tresp, M. U. Hammer, K.-D. Weltmann and S. Reuter, *Plasma Med.*, 2013, 3.