



**HAL**  
open science

# PREDICTIONS & MODELING ENERGY CONSUMPTION FOR IT DATA CENTER INFRASTRUCTURE

Philippe Roose, Merzoug Soltane, Derdour Makhlof, Kazar Okba

► **To cite this version:**

Philippe Roose, Merzoug Soltane, Derdour Makhlof, Kazar Okba. PREDICTIONS & MODELING ENERGY CONSUMPTION FOR IT DATA CENTER INFRASTRUCTURE. *Advances in Intelligent Systems and Computing*, 2018, Tanger, Morocco. pp.1-11. hal-02437210

**HAL Id: hal-02437210**

**<https://univ-pau.hal.science/hal-02437210v1>**

Submitted on 13 Jan 2020

**HAL** is a multi-disciplinary open access archive for the deposit and dissemination of scientific research documents, whether they are published or not. The documents may come from teaching and research institutions in France or abroad, or from public or private research centers.

L'archive ouverte pluridisciplinaire **HAL**, est destinée au dépôt et à la diffusion de documents scientifiques de niveau recherche, publiés ou non, émanant des établissements d'enseignement et de recherche français ou étrangers, des laboratoires publics ou privés.

# ***PREDICTIONS & MODELING ENERGY CONSUMPTION FOR IT DATA CENTER INFRASTRUCTURE***

Merzoug soltane  
Department of computer sciences.  
El-oued University  
El-oued, Algeria  
[merzoug-soltane@univ-eloued.dz](mailto:merzoug-soltane@univ-eloued.dz)

Derdour Makhlof  
Department of computer sciences  
Tebessa University  
Tebessa, Algeria  
[m.derdour@yahoo.fr](mailto:m.derdour@yahoo.fr)

Philippe roose  
LIUPPA,  
University of Pau et Pays de l'Adour  
Anglet, France  
[Philippe.roose@univ-pau.fr](mailto:Philippe.roose@univ-pau.fr)

Kazar okba  
Department of computer sciences  
Biskra University  
Biskra, Algeria  
[kazarokba@gmail.com](mailto:kazarokba@gmail.com)

**Abstract**— Recent statistics of energy consumption by Cloud datacenter show the DCs consumes more and more energy each year .that crated big challenge in Cloud research. IT industry is keenly aware of the need for Green Cloud solutions that save energy consumption in Cloud DCs. A great deal of attention has been paid to minimize energy consumption in cloud datacenter. However, to understand the relationships between running tasks and energy consumed by hardware we need to propose mathematical models of energy consumption. The models of energy consumption can be help as to saving energy. Both researchers aim to proposed mechanism for energy consumption. In this paper, we analyzed the relationships between Cloud system manager and energy consumption. This paper aims at proposing and designing energy consumption models with mechanism of prediction energy.

**Keywords**—energy consumption ; energy modeling; energy predictions; datacenter energy consumption

## I. INTRODUCTION

Today, both researchers and engineers aim to minimize energy consumption based on energy modeling, because is one of the most important researches in Cloud computing [1].

However, the fast evolution of cloud datacenter created really problem of energy consumption. For example a typical datacenter needs 10 megawatts of power to operate [1], in 2013 [2], the Datacenter in the USA consumed 91 billion of electricity (kW /h) costing US businesses 13\$ billion per year for electricity bills and generating nearly 100 million tons of carbon pollution (CO<sub>2</sub>) per year.

Nowadays, the modeling of energy consumption become very complicated because the scale of datacenter becomes larger and larger, the energy consumption of datacenter becomes bigger, each level of service cloud like (SaaS, PaaS, IaaS) has different energy consumption methods and these methods can't be used or migrated between each level of cloud.

Another problem of energy prediction in cloud datacenter make a lot of researchers and engineers eager to work on the development of predictive energy consumption mechanisms. However, in order to further predict future energy consumption researchers need to build energy model by their own. During the modeling of energy consumption, researchers need to capture the relationships between hardware resources and their energy consumptions.

In this paper, we analyzed the energy consumption of datacenter by each computing ressources, analyzed different energy consumption model, and analyzed performance on predicting energy consumption by all datacenter ressources. The contribution of the paper are as follows:

- i. Proposed datacenter Rack power diagram to show 3 levels of power consumption
- ii. We analyzed related work of energy consumption and we proposed energy consumption models
- iii. We analyzed prediction energy consumption by all resources of datacenter and we proposed our prediction mechanism
- iv. We implemented first part of datacenter infrastructure in cloud simulation

The rest of the paper is organized as follows, section 2 describes related work about energy prediction and energy modeling , In section 3, all detailed of our contribution .Experiments and conclusion are in sections 4 and 5 , respectively.

## II. RELATED WORKS

To understand and control the energy consumption of a datacenter, we need first understand energy management mechanisms to identify all sources of energy consumption to help as to building energy model framework. This section of literature review covers and shows the different techniques in many axis of energy consumption model and energy prediction.

### A. Energy consumption module

The difference between power and energy is very important, because reduction of the power consumption does not always reduce the consumed energy, multiple work have been done to model the energy consumption can be classified into (module for hardware components, software components)

For processor energy consumption modeling work, first we find Shao *et al.* developed an instruction-level energy model for Intel Xeon Phi processor, which is the first commercial many core/multi-thread x86-based processor [3]. They developed an instruction-level energy model for Xeon Phi through the results obtained from an energy per instruction (*E<sub>pi</sub>*) characterization made on Xeon Phi.

In the same line of research we find, Kliazovich et al [4] modeled the energy of server by power and frequency of CPU and a constant. In their model, all components except for CPU where considered constant. Same authors in another paper [5], described an energy model of the whole datacenter, where computing nodes were liners model of CPU utilization, and switch was multivariate function. Another work, which is almost similar. Lee et al [6] used the maximal power and minimal power, current power of CPU to model the energy consumption.

Up to now, we have focused on energy consumption models based on physical characteristics of the data center. Equally important is to consider the type of software application of a datacenter. After analysis, we can broadly categorized datacenter software into two categories: *the Operating System/Virtualization layer and the applications.*

There has been a number of works on datacenter application energy modeling, like Smith *et al* [7]. Described “Application Profiles,” which is a means for presenting resource utilization of distributed application deployment. The Application Profiles they developed captures usage of the CPU, memory, hard disk, and network accesses. They described “Cloud Monitor,” a tool that infers the energy consumption from software alone with computationally generated power models. Krishnan et al.[8] proposed a VM power consumption model using two hardware PMC events such as instruction retired (inst ret/sec) and LLC(Last Level Cache) misses for modeling power consumption of CPU, and memory.

In another hand, it is important to understand the energy consumption of OS level. Did One such characterization was done by Li *et al.* [9], which characterized the behavior of a OS across a large spectrum of applications to identify OS energy profiles and proposed OS energy consumed model. The OS

energy consumption profiling gave a breakdown of power dissipation of OS routines, this study show the multiple application execution are found to consume 50% of total power on the examined OS routines. The capacitive load to the network causes significant power consumption about 34%.

### B. Energy prediction

In this sup-section, we present relevant approaches proposed in the literature for prediction energy.

Some works of prediction energy addressed to optimize power consumption in cloud datacenter, Hieu et al [10] proposed Virtual machine consolidation algorithm with usage prediction (VMCUP) for improving the energy efficiency of cloud data centers. The proposed algorithm executed during the virtual machine consolidation process to estimate the short-term future CPU utilization based on the local history of the considered servers. The joint use of current and predicted CPU utilization metrics allows a reliable characterization of overloaded and under-loaded servers, thereby reducing both the load and the power consumption after consolidation.

Farahnakian et al [11] presented a linear regression based CPU usage prediction (LiRCUP), for VM migration. Specifically, the authors estimated the future CPU usage to predict overloaded and under-loaded hosts; then, some of VMs are migrated to other hosts before a SLA violation occurs. Consequently, such a solution relies on early migration of VMs even when the current resource usage of the considered hosts is still acceptable, thus resulting in unnecessary migrations.

In the same line of research, Dhiman et al. [12] proposed a power modeling methodology based on Gaussian Mixture Models that predicts power consumption by a physical machine running multiple VM instances. The proposed approach requires a training phase to perceive the relationship between the metrics of the workload and the power consumption. The authors have evaluated the proposed model via experimental studies involving different types of the workload. The obtained experimental results have shown that the model predicts the power consumption with high accuracy (<10% prediction error), which is consistent over all the tested workloads.

## III. DATACENTER ENERGY MODELING

In this section, we describe how we organized resources of datacenter. We designed the flow of electrical power between all levels of datacenter (DC) resources fig 1. A more detailed presented in Fig 2 the latter figure provides an overview of the organization of DC energy consumption modeling.

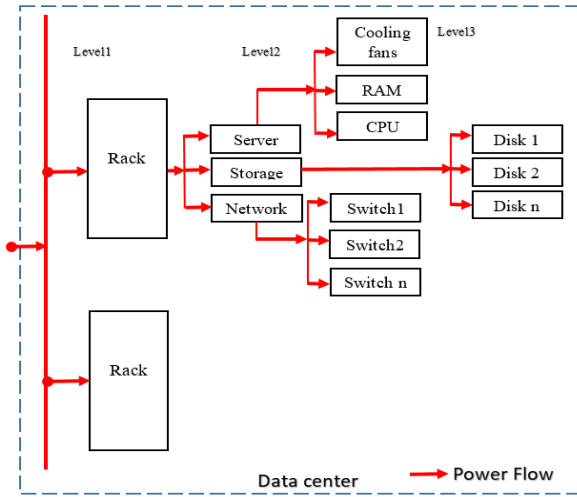

Figure 1: Rack power flow in datacenter

- Level 1: contained rack installed in a datacenter.
- Level 2: contained servers, storage server, and network equipment.
- Level 3: contained all resources like (CPU, RAM, Disk, Switch,).

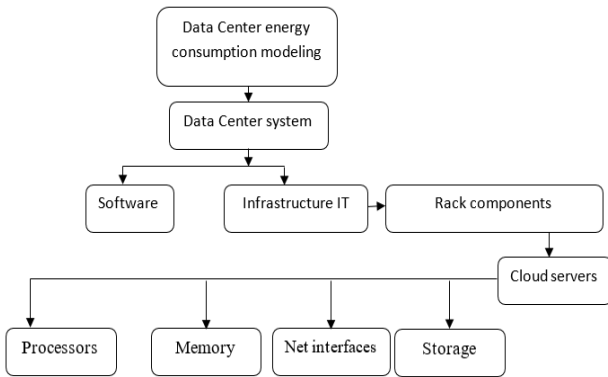

Figure 2: Rack power flow in datacenter

#### A. Model of power consumption

In this sub-section, we describe detailed of our models of energy consumed in each level

##### Level1 (Rack power)

$$P. \text{rack} = \text{power of all resources installed in the rack} \\ = (P. \text{CPU} + P. \text{RAM} + P. \text{CoolingF}) + (P. \text{Disk}) + (P. \text{Switch})$$

##### Level2 (power consumption for server)

The energy consumed by the server S computes according to the following formula

$$P. \text{Server} = \text{All energy consumed by all components of this server} \\ = (P. \text{CPU}) + (P. \text{RAM}) + (P. \text{CoolingF})$$

Model of power consumption for storage components

$$P. \text{Storage} = (P. \text{ActiveDisk} * M)$$

m= total number of Active disk storage

Model of power consumption for network equipment

$$P. \text{Network} = (P. \text{Switch} * N)$$

n= total number of Active switch

##### Level3

#### PROCESSOR POWER CONSUMPTION

Today, Modern processors such as Intel Xeon consist of multiple billions of transistors, which make them utilize huge amount of energy. Because of these, powerful CPU considered the one of the largest power consumers of a server, the major categories of processors used in current datacenter systems multi-core CPU.

We modeling CPU activity in server (s) associate with allocation new VM its consumption brought to the server. This value represents the increase consumption induced by the hosting of this new VM on this server.

$$P. \text{Cpu}(Vm, S) = Cpu(Vm) + \frac{(P. \text{active}(S) * \mu) - (P. \text{idel}(S) * \mu)}{Cpu \text{ max}(S)}$$

**P.Cpu (Vm,s):** represents the energy consumed by CPU when server S allocated new VM

**P.active (S):** represents power consumed by active CPU in server S

**P.idel (S):** represents power consumed by inactive CPU in server S

**CPU max(s):** represents max power consumed by CUP in server S

**CPU (Vm):** represents allocated CPU in new virtual machine

**μ:** CPU utilization rate

#### MEMORY POWER CONSUMPTION

The memory is the second largest energy consumer in a server consumes about ≈30% of the total power. IT equipment such as servers comprise of a memory hierarchy. The rapid increase of the memory capacity and bandwidth has contributed for memory sub system to consume a significant portion of the total server power.

We modeling RAM energy consumed in server (s) associate with new request of allocation VM its consumption brought to the server. This value represents the increase consumption induced by the hosting of this new VM on this server.

$$P. \text{Ram}(Vm, S) = RAM(Vm) + \frac{(P. \text{active}(S) * \delta) - (P. \text{idel}(S) * \delta)}{RAM \text{ max}(S)}$$

**P.Ram (Vm,s) :** represents the energy consumed by RAM when server S allocated new VM

**P.active (S):** represents power consumed by active Ram in server S

**P.idel (S):** represents power consumed by inactive Ram in server S

**RAM max(s):** represents max power consumed by RAM in server S

**RAM (Vm):** represents allocated RAM in new virtual machine

**δ:** RAM utilization rate.

### COOLING FANS POWER CONSUMPTION

We modeling cooling fans energy consumed in server (s) related with application run in the server. This value represents the increase consumption induced by the hosting new run application on this server.

$$P.Cool(S) = \frac{\sum P.ActiveFans}{P.max(S)}$$

**P.cool (S)** = represents the energy consumed by cooling system in server S

**P.activeFans**= represents the energy consumed by each active fans in server S

**P max(s)**: represents max power consumed by server S

### STORAGE POWER CONSUMPTION

Hard Disk is currently the main type of storage media used in data center servers. The rapid increase of the hard disk capacity impact positively on mass storage of data center servers hi can storage to 20 Terabit.

We modeling energy consumed by storage capacity in server (s) related with the allocation of new VM.

$$P.storag(Vm,S) = Storag(Vm) + \frac{(P.activeDisk(S))}{P.max(S)}$$

**P.storag (Vm.s)**: represents the energy consumed by storage when server S allocated new VM

**P.activeDisk (S)**: represents power consumed by active disk storage in server S

**Storage (Vm)**: represents storage capacity allocated for a new virtual machine

**P max(s)**: represents max power consumed by server S

### NETWORK POWER CONSUMPTION

Network interface is a significant contributor to the system power consumption, consume between (10% to 7%) can be either in idle mode or in active (either receiving or transmitting packets) mode, the total energy consumption of the network interface can be represented as

We modeling energy consumed by network switch based on stat of each interface, we define tow stat for network interface (active interface, idle interface).

$$P.Switch = (\sum P.Active.interface) + (\sum P.idle.interface)$$

### B. Our proposed mechanism of Prediction

The proposed model is a combination of a several sub models (VM resource tracing, workload controller, management system resources and power tracing, base model of prediction, energy calculation model be on our proposed model of energy consumption). To estimate the energy consumption from our predicted mechanism and the remaining measurable parameters of energy consumption. We give

detailed overview of the proposed model with its inputs and outputs given in Figure 3.

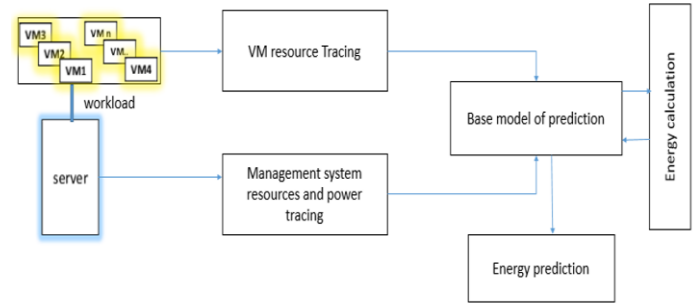

Figure 3. Detailed of model of prediction for energy consumption

- **VM resources tracing:** This model tracks the state of all virtual machines allocating in the server. More precisely this model follows the resources allocated for each VM and control their energy consumption.
- **Management system resources and power tracing:** This model follows the state of all PMs. More precisely, this model tracks the physical resources installed and allocated in each server and controlled the energy consumption by each PM.
- **Workload controller:** this model control all allocation request. Moreover, send information of each allocation request to VM resources tracing model
- **Energy calculation model:** this model based on our energy consumption model.
- **Base model of prediction:** this model base in algorithm of prediction to give estimated energy consumption by the system.

### Algorithm of prediction

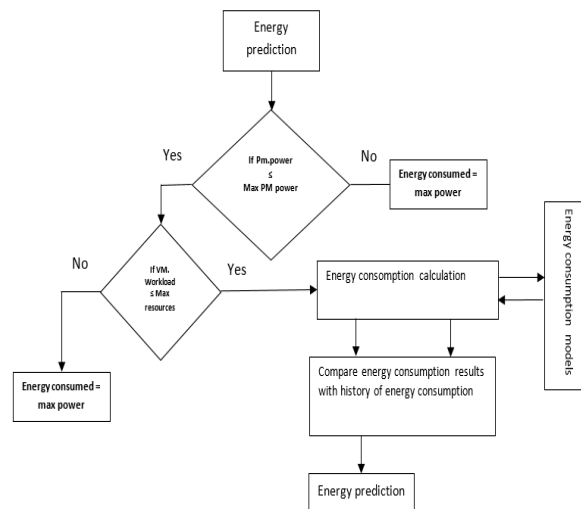

Figure 4: chart of prediction algorithm

Prediction energy	
Input:	(i) VM resources information (ii) server power information (iii) energy calculation
Output:	(o) resources needed, (o) energy needed
1:	at the end of each period, checks the latency of each VM
2:	calculate the utilization resources rate by each VM, with the sum of the latencies
3:	calculate the number of physical CPUs used
4:	calculate the number of RAMs used
5:	calculate the size of storage space used
6:	For a period of time ( $T_i$ ) do
7:	if ((VM latency) is always < predetermined threshold) and (resources allocate < Max servers resources) then
8:	calculate energy consumption
9:	if (new resources allocate + previous resources allocate < predetermined threshold) then
10:	Compare energy consumption results with history of previous energy consumption
11:	Dertimneted energy consumption for courant time ( $T_i$ ) predetermined by our system
12:	give prediction energy needed for next $T_{i+1}$ based on energy consumption for courant time ( $T_i$ )

#### IV. IMPLEMENTATION AND EVALUATION

To evaluate performance, we simulated our algorithm and model of energy consumption using the ICan Cloud simulator, which is a graphical runtime environment for network simulation. We simulated scenario for allocating resources subsequently, we implemented one cloud computing service provider to offer cloud services to users, and the datacenter implemented for this cloud runs many servers as shown in table 1. C++ used to evaluate the performances of our prediction strategies. We tested them with a number of user requests to show the performances of our algorithm, such as global energy prediction and energy consumption

TABLE I. DATACENTER RESOURCE

N°DC	Datacenter resource		
	Rack	Server	storage
1	100	Cpu dual core Ram 16 g	1To

#### A. SIMULATION RESULTS

Figure 5: simulation result

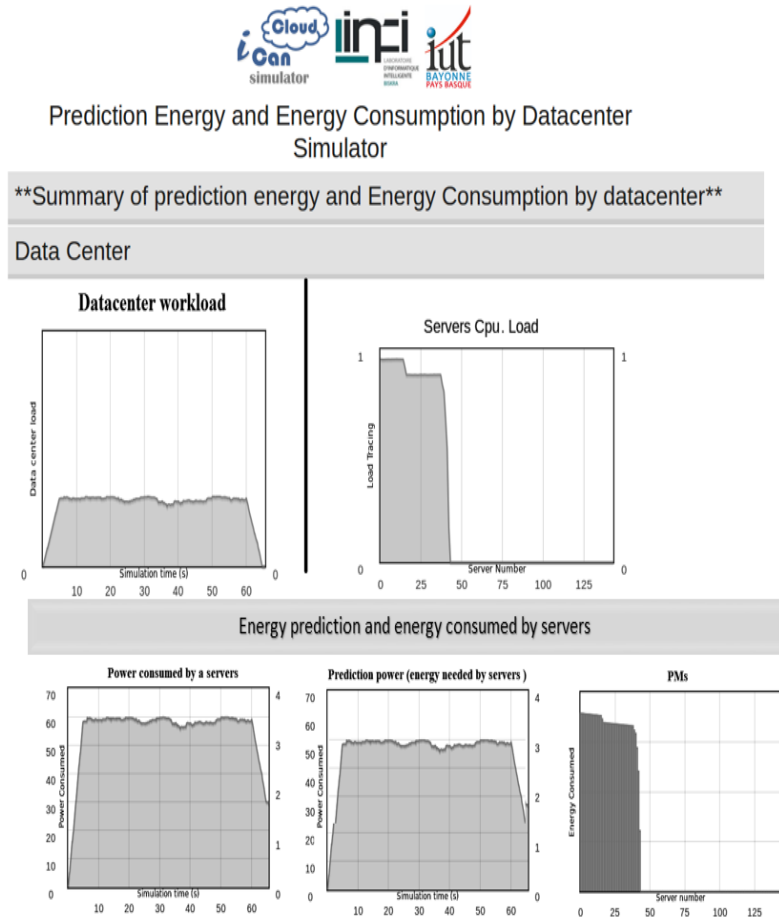

Figure 5 illustrates graphical presentation of simulation our prediction energy strategies and energy consumption by datacenter

Figure 5 shows the energy consumption rate compared with energy prediction rate. When we apply our proposed algorithm in this work, we observe the remarkable good prediction of energy consumed. This result of prediction shows the performance of our model of power consumption and our prediction strategy and confirms our choice to use modeling approach to measure the energy needed to ruining datacenter resources.

#### V. CONCLUSION

We introduced the problem of power consumption by cloud datacenters. Then, we presented in this paper modeling approach to measured energy consumed by each resources in datacenter. We combined prediction strategies with our model of power to calculate power consumption. The simulation aims to clarify the efficiency of the internal function (tracing energy consumed by each resources), and the external function (the energy consumption and energy predicated). In the future, we plan to develop more models of energy consumption with a version of the prediction algorithm with more intelligence.

## VI. REFERENCES

- [1] Hooper, A. (2008). Green computing. *Communication of the ACM*, 51(10), 11-13.
- [2] <https://www.nrdc.org/resources/americas-data-centers-consuming-and-wasting-growing-amounts-energy>
- [3] Y. Shao and D. Brooks, "Energy characterization and instruction-level energy model of Intel's Xeon Phi processor," in *Proc. IEEE ISLPED*, Sep. 2013, pp. 389–394..
- [4] Kliazovich, D., Bouvry, P., & Khan, S. U. (2012). GreenCloud: a packet-level simulator of energy-aware cloud computing data centers. *The Journal of Supercomputing*, 62(3), 1263-1283.
- [5] Kliazovich, D., Bouvry, P., & Khan, S. U. (2013). DENS: data center energy-efficient network-aware scheduling. *Cluster computing*, 16(1), 65-75.
- [6] Lee, Y. C., & Zomaya, A. Y. (2012). Energy efficient utilization of resources in cloud computing systems. *The Journal of Supercomputing*, 60(2), 268-280.
- [7] J. Smith, A. Khajeh-Hosseini, J. Ward, and I. Sommerville, "Cloudmonitor: Profiling power usage," in *Proc. IEEE 5th CLOUD Comput.* Jun. 2012, pp. 947–948
- [8] Krishnan Bhavani, Amur Hrishikesh, Gavrilovska Ada, and Schwan Karsten. VM power metering: feasibility and challenges, *ACM SIGMETRICS Performance Evaluation Review*, 38:56–60, 2011..
- [9] T. Li and L. K. John, "Run-time modeling and estimation of operating system power consumption," in *Proc. ACM SIGMETRICS Int. Conf. Meas. Model. Comput. Syst.*, 2003, pp. 160–171.
- [10] Hieu, N. T., Di Francesco, M., & Ylä-Jääski, A. (2015, June). Virtual machine consolidation with usage prediction for energy-efficient cloud data centers. In *Cloud Computing (CLOUD)*, 2015 IEEE 8th International Conference on (pp. 750-757). IEEE.
- [11] Farahnakian, F., Liljeberg, P., & Plosila, J. (2013, September). LiRCUP: Linear regression based CPU usage prediction algorithm for live migration of virtual machines in data centers. In *Software Engineering and Advanced Applications (SEAA)*, 2013 39th EUROMICRO Conference on (pp. 357-364). IEEE.
- [12] G. Dhiman, K. Mihic, and T. Rosing, "A system for online power prediction in virtualized environments using Gaussian mixture models," in *Proc. 47th DAC*, 2010, pp. 807–812.